

TAPASYA

DESIGNING SOLUTIONS
DELIVERING INNOVATION

PHARMACEUTICALS

NUTRACEUTICALS

CHEMICALS

COSMETICS

FOOD



THE SINGLE STOP SOLUTION PROVIDER, PAR EXCELLENCE

Tapasya is renowned for its contribution to the Pharmaceutical, Nutraceutical, Food, Chemical, Cosmetics and other allied industries as a Single Stop Solution Provider for Solid Formulations and much more. Started in 1962, its experience, spanning over 5 decades has added immense value to the granulation, drying, milling, blending, micronising, coating and pelletising processes of innumerable companies in India and world over. Its products, are utilised by the top Pharma companies of India and its granulation system, Saizoner, is the market leader among 'High Shear Mixer Granulators'.

Tapasya's distinction lies in its ability to offer individual solutions tailored to varied requirements, ranging from a lab scale production of a few grams to a commercial scale output of many tonnes a day.

Backed by deep-rooted values of, 'Integrity, Ownership, Passion, Achievement orientation, Adaptability, Innovation and Team spirit', it is Tapasya's vision to be a 'World class enterprise providing Integrated Solutions to the Pharma and allied industries.'

Tapasya, in collaboration with distinguished international partners, also provides novel technological solutions in the following specialised areas:

- Containment material handling system, through our German partner Andocksysteme G.
- Comprehensive assortment of liquid filling and packing systems for pharma and beverage industry from Fill Technic, Turkey

CONTENTS

GRANULATING

- HIGH SHEAR MIXER GRANULATOR _____ 06
- HIGH SHEAR MIXER GRANULATOR - R2T _____ 11
- BINDER PREPARATION VESSEL _____ 14

DRYING

- FLUID BED EQUIPMENT _____ 18
- TRAY DRYER _____ 23
- ROTO CONE VACUUM DRYER _____ 26

MILLING

- TAP CONE MILL _____ 30
- UNDER DRIVEN CONE MILL _____ 33
- MULTI MILL _____ 36
- SIFTER CUM MULTI MILL _____ 39
- OSCILLATING GRANULATOR _____ 42
- VIBRATORY SIFTER _____ 45
- DELUMPER _____ 48

BLENDING

- 'V' BLENDER _____ 52
- CONTA BLENDER _____ 55
- OCTAGONAL BLENDER _____ 58
- DOUBLE CONE BLENDER _____ 61
- RIBBON BLENDER _____ 64
- PLOUGH SHEAR MIXER _____ 67

MATERIAL HANDLING

- ELEVATOR _____ 72
- TIPPER _____ 75
- POWER TRANSFER SYSTEM _____ 78
- IBC (IN-PROCESS BATCH CONTAINER) _____ 81
- PALLET WEIGHING TRUCK _____ 84

CLEANING

- BIN WASH System _____ 88
- CIP / WIP SKID _____ 91

TABLET COATING

- AUTO COATER _____ 96

GRANULATING

Wet agglomeration processes have traditionally been considered an empirical art, the three key areas of wet granulation processes are wetting and nucleation, consolidation and growth, and breakage and attrition.

HIGH SHEAR MIXER GRANULATOR_____06

HIGH SHEAR MIXER GRANULATOR - R2T_____11

BINDER PREPARATION VESSEL_____14

HIGH SHEAR MIXER GRANULATOR

Tapasya's High Shear Mixer Granulator is designed to meet special needs of tablet formulation technology. This is achieved by reducing processing time, homogeneous mixing, even distribution of binder, wetting, nucleation and granule size growth with sampling provision for in process analysis and proven safety during processing, compliant to cGMP norms.

Tapasya's High Shear Mixer Granulator is designed to meet the special needs of drying of Pharmaceuticals (Formulations and Bulk Drugs). It offers a controlled, channelised process in a quest to achieve product homogeneity, fluidity, stability by lower heat transfer, clean & hygienic air medium using pneumatics, superior MOC, proven manufacturing expertise and application of cGMP at all stages.



Features:

- Unique design incorporating Impeller, Granulator, Online Co-mill, Side discharge valve & dryer
- Internal and External surfaces of Mixing Bowl, Mixing Bowl cover, Impeller, Granulator, and Discharge Chute constructed in SS 304/316L
- Specially mounted torque sensor arrangement for critical parameters of granulation like end point determination & desired granule profile
- Impeller Lifting Options:
 - Pneumatically Operated Bottom Impeller Lifting for ease of cleaning
 - Electromechanical impeller lifting and removing mechanism
- Hydraulically operated Lid lifting
- Parts easy to dismantle, clean and re-assemble
- Pneumatics pre-tubed
- Gaskets of Teflon / Silicon
- Bowl surface finish of 0.3RA (inside / outside)
- ATEX Compliant option available
- Customised capacities available
- Optional features of Jacketed models, Vacuum / Gravity Charging, Mechanical Seals, Binder spraying systems, CIP / WIP systems, Vacuum drying, Scada Solutions available
- Drying under vacuum, at lower temperature with solvent recovery system
- Optional features for dryer include PLC control with printer, Turnkey with hearing, vacuum and solvent recovery system



Specially designed Radial Impeller



'C' shaped standard chopper



Online wet Co mill



Product charging through gravity transfer



Product charging through closed loop vacuum transfer

Features:

- Multiple options available for Impeller blade, Chopper and Co mill blade and screen
- In-house pressure tested 2 Bar HSMG

Level of Instrumentation:

Parameter	Indication	Record	Control	Alarm	Interlock	Export
Impeller Speed	√	√	√	√	√	√
Chopper Speed	√	√	√	√	√	√
Processing Times	√	√	√			Time Start, Time Finish
Product Temperature	√	√		√		
Impeller Power	√	√	√	√	√	√
Loading	√				√	Time Start, Time Finish
Lid Position	√			√	√	
Valve Positions	√			√	√	
WIP Mode	√		√			

IPC - PLC based Automation Control

Benefits For You:

- Single equipment for Mixing-Granulating-Drying
- Uniform distribution of all formulation ingredients
- Short mixing and granulation time to achieve desired granules profile
- Useful working capacity of upto 80% to 30% of bowl volume
- Uniform granules by gentle processing
- Wide range of applications
- Easy scale up & Scale down between machine sizes
- Bowl shape designed to have no dead spaces
- Fully Automated System for QBD compliant
- Standard documentation package provided
- Designed to meet cGMP requirements
- Designed to check leakages & prevent cross-contamination & also designed with inbuilt safety checks
- Final product of superior quality due to low attrition, lower drying temperature and time



Granulator - Dryer



Vacuum rated bowl



Mimic Display for Process Monitoring and Control

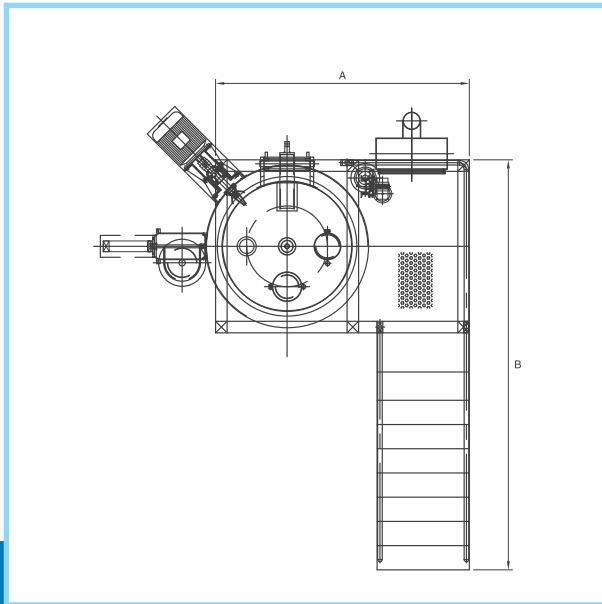

Plan view

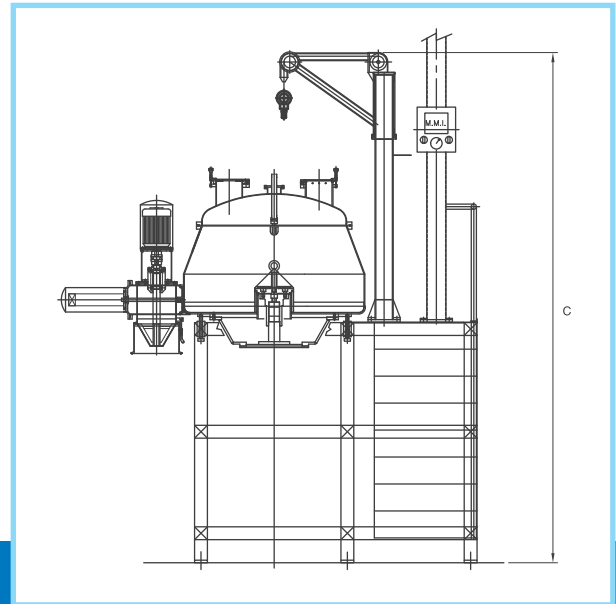

Elevation view

Technical Specifications:

MODEL	WORKING CAPACITY (in Liters)	OVERALL DIMENSIONS (in mm)			MOTOR HP	APPROX. WEIGHT (in kg)
		Length	Width	Height		
TAP-HSMG-MINI (Lab Scale with Interchangeable Bowls)"	1	1000	1000	1200	2	200
TAP-HSMG-10 (Lab Scale with Interchangeable Bowls)"	8	610	1200	1400	2	500
TAP-HSMG-25	20	1500	1800	1900	7	1000
TAP-HSMG-50	40	1500	2300	1900	10	1200
TAP-HSMG-75	60	2300	2600	2400	15	1500
TAP-HSMG-100	80	3000	2500	3000	21	1700
TAP-HSMG-150	120	3000	2800	3000	21	2000
TAP-HSMG-200	160	2500	2700	2700	28	2300
TAP-HSMG-250	200	2600	2800	2900	38	2500
TAP-HSMG-300	240	2700	2900	3200	38	2500
TAP-HSMG-400	320	2700	3100	3300	48	3000
TAP-HSMG-600	480	2800	3250	3500	62.5	3500
TAP-HSMG-800	640	2900	3400	3800	72.5	3500
TAP-HSMG-1000	800	3100	3600	4100	82.5	4000
TAP-HSMG-1200	960	4500	4600	5600	105	4300
TAP-HSMG-1400	1120	4500	4600	5600	120	4500
TAP-HSMG-1800	1360	4200	4100	5900	140	4800

OEB5 compliant containment models from our **SHIELD 5** Series are available
 12 Bar Explosion proof models from our **SHIELD 12** Series are available

High Shear Mixer Granulator used in Industries:

- Pharmaceutical
- Nutraceutical

HIGH SHEAR MIXER GRANULATOR – R2T

Tapasya's HSMG enjoys the trust and confidence of customers, the world over, for its unparalleled quality, unique features and reliable performance. Being the world leader in 'High Shear Mixer Granulators', Tapasya's quest for continuous improvement of the product was constantly fuelled by its competent 'Design & Development Team.'

Tapasya, the leader in HSMG, never rested on its laurels and worked purposefully towards enhancing the product for its customers. Improvement is design coupled with innovation in technology, the hallmark of Tapasya, has led to the launch of 'HSMG – R2T', the only one of its kind in the world today.

In HSMG-R2T, Tapasya has, for the '1st Time in the World', introduced the feature of 'Direct Drive Technology' in Granulators. It is the only Granulator that not only meets all the stringent quality requirements of the FDA / cGMP, but also meets the specific needs of customers, with its , distinct 'Torque-based' granulation end-point determination.



R2T: Distinct Edge over Conventional Granulators:

- Increase in productivity due to unique R2T technology (Upto almost 50%, as per data shared by customers)
- Greater accuracy in determining and validating granulation endpoint
- Superior performance of the machine with 100% accuracy, due to Direct Drive Motor
- Improved Efficiency as minimal maintenance needs, due to elimination of conventional machine components such as, belts, pulley drives, worm & worm wheel gearbox, etc.
- Reduced number of batches for validation of product to commercial level, due to precise Granulation endpoint
- Major savings and cost containment due to absence of drive elements, improved efficiency of 85% and savings in power bills upto 12%
- Meets all requirements of cGMP

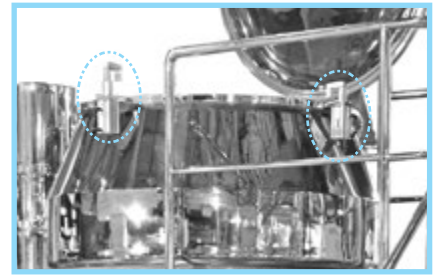

Pneumatic Lid Lock



Screwless Panel



Sleek Ladder Design

Torque (NM) Vs Current (A) of TAP-HSMG-R2T-300

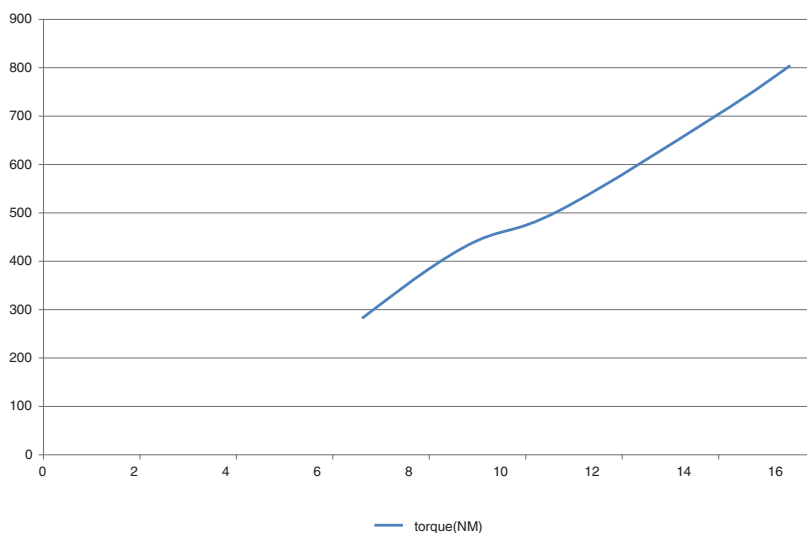

Monitoring granulation profile with respect to impeller shear

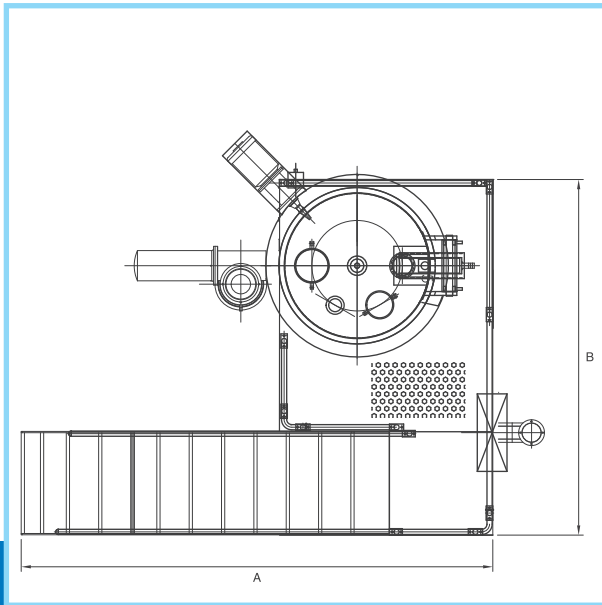

Plan view

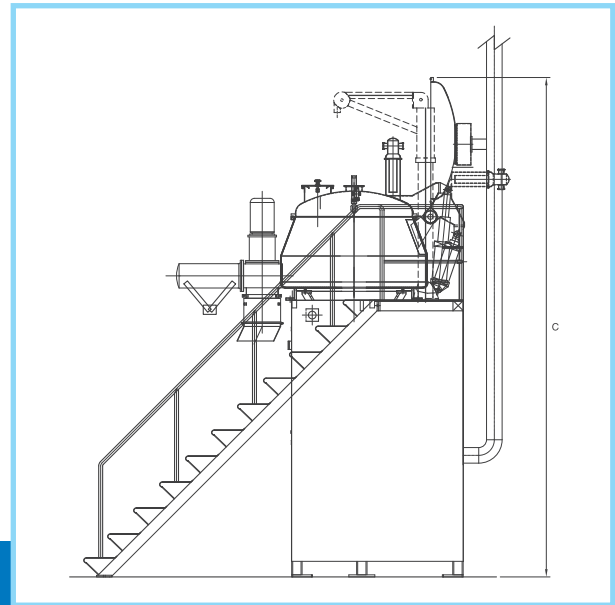

Elevation view

Technical Specifications:

MODEL	WORKING CAPACITY (in Liters)	OVERALL DIMENSIONS (in mm)			SPECIAL R2T Technology	APPROX. WEIGHT (in kg)
		Length	Width	Height		
TAP-HSMG-MINI (Lab Scale with Interchangeable Bowls)"	0.8	1000	1000	1200	30	200
TAP-HSMG-10 (Lab Scale with Interchangeable Bowls)"	8	610	1200	1400	30	500
TAP-HSMG-25	20	1500	1800	1900	230	1000
TAP-HSMG-50	40	1500	2300	1900	230	1200
TAP-HSMG-75	60	2300	2600	2400	500	1500
TAP-HSMG-100	80	3000	2500	3000	500	1700
TAP-HSMG-150	120	3000	2800	3000	500	2000
TAP-HSMG-200	160	2500	2700	2700	600	2300
TAP-HSMG-250	200	2600	2800	2900	600	2500
TAP-HSMG-300	240	2700	2900	3200	1500	2500
TAP-HSMG-400	320	2700	3100	3300	1500	3000
TAP-HSMG-600	480	2800	3250	3500	1500	3500
TAP-HSMG-800	640	2900	3400	3800	2500	3500
TAP-HSMG-1000	800	3100	3600	4100	2500	4000
TAP-HSMG-1200	960	4500	4600	5600	3000	4300
TAP-HSMG-1400	1120	4500	4600	5600	3000	4500
TAP-HSMG-1800	1360	4200	4100	5900	3500	4800

OEB5 compliant containment models from our **SHIELD 5** Series are available
 12 Bar Explosion proof models from our **SHIELD 12** Series are available

High Shear Mixer Granulator – R2T used in Industries:

- Pharmaceutical
- Nutraceutical
- Food
- Cosmetics

BINDER PREPARATION VESSEL

Tapasya's Binder Preparation Vessel (Paste Preparation Kettle) has been designed uniquely for optimal mixing efficiency so as to ensure a homogeneous mix. The special stirrer in the vessel has been designed to create vortex inside the solvent which enhances the desired solubility of pharmaceutical binder solute into the various solvents.

Due to its unique design the binder solution can be directly transferred into the processing equipment such as high shear mixer granulator, planetary mixers or fluid bed processor.

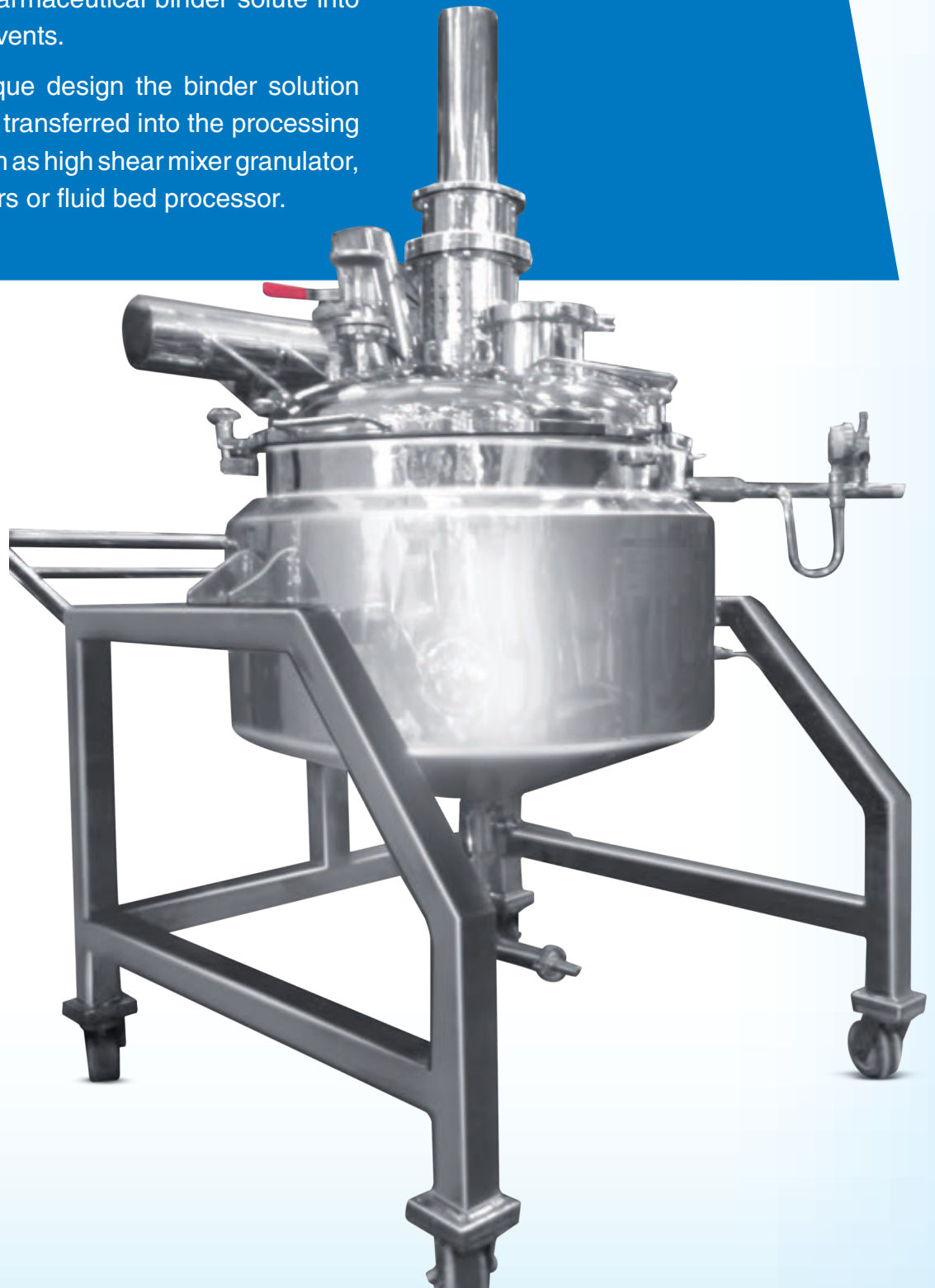

Features:

- Designed uniquely for optimal mixing efficiency
- Special stirrer included for homogenous mix
- Controlled temperature exposure with special jacketed bowl
- Variable rotation rate possible
- Custom-made capacity
- Integration of flow rate control assembly into system
- Direct transfer of binder solution to granulation processing equipment
- Cleaning & maintenance easy

Benefits For You:

- Optimal mixing efficiency to ensure a homogeneous mix
- Easy handling
- Easy maintenance



Close view of Binder Vessel Lid

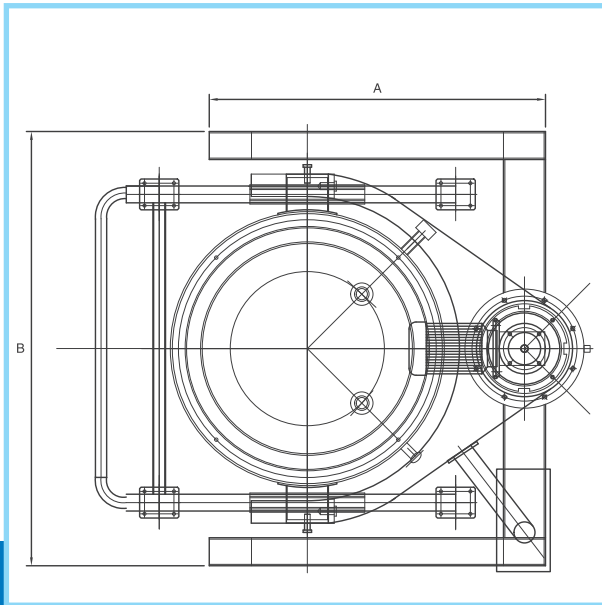

Plan view

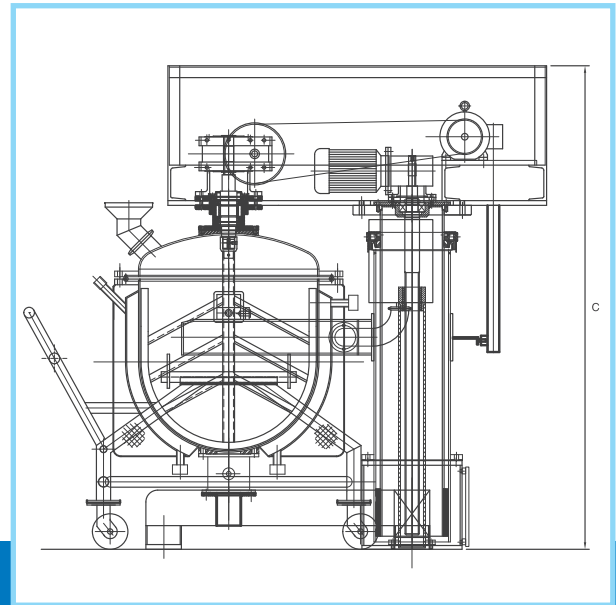

Elevation view

Technical Specifications:

MODEL	WORKING CAPACITY (in Liters)	OVERALL DIMENSIONS (in mm)			MOTOR HP	APPROX. WEIGHT (in kg)
		Length	Width	Height		
TAP-BPV-50	35	1000	1100	1200	1	100
TAP-BPV-60	42	1170	1100	1700	1	120
TAP-BPV-100	70	1800	1500	1900	2	150
TAP-BPV-120	84	2300	2600	2400	2	180
TAP-BPV-150	105	3000	2500	3000	3	200
TAP-BPV-200	140	3000	2800	3000	5	230
TAP-BPV-250	175	2500	2700	2700	5	250
TAP-BPV-350	300	2600	2800	2900	7.5	300

Customised sizes available on request

Binder Preparation Vessel used in Industries:

- Pharmaceutical
- Nutraceutical
- Food
- Cosmetics

DRYING

Drying involves diffusion of water through the material into the passing steam air, uniformity in drying enhance the robustness of the formulation and processes.

FLUID BED EQUIPMENT _____ **18**

TRAY DRYER _____ **23**

ROTO CONE VACUUM DRYER _____ **26**

FLUID BED EQUIPMENT

Tapasya's Fluid Bed Equipment (FBE) is specially designed unit for agglomeration and simultaneous drying for top spray granulation conforming to the international quality norms and with all latest features incorporated. Built with a working pressure of 2 Bar at 80 degree C, the drying capabilities of our FBDs are enhanced by 18 - 20%, resulting in lesser drying time and uniform fluidization. Air Handling System is specially designed for evenly distribution of Heat to the material to be dried in order to supply the latent heat required for vaporization of the moisture. The fully automated system is designed to achieve robust formulation and stringent cGMP compliance.

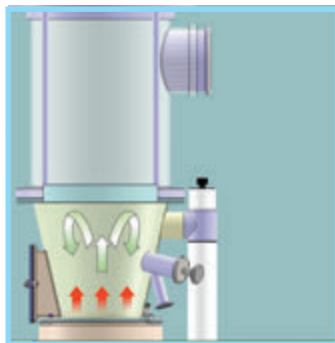

Batch fluid bed Drying

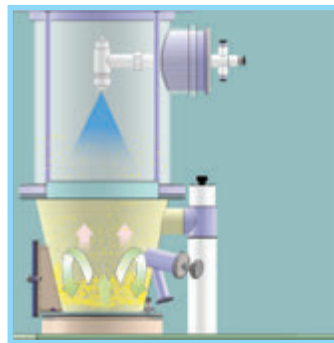

Batch fluid bed Top Spray

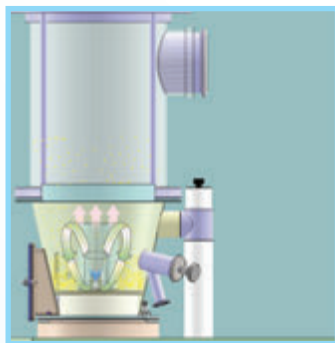

Batch fluid bed Bottom Spray



Features:

- FBE suitable for granulation and drying for accurate process parameters
- Online charging from HSMG into FBE using vacuum. Inlet feed port with SS gas tight pneumatic actuated valve
- Closed loop discharged system from FBE into mill using pneumatic conveying systems
- Temperature control with a +/- 1° C (process accuracy)
- Humidity control over entire operating range ± 5% (process accuracy)
- Technical support in critical areas of validation at different levels of scaleup
- Process accessibility for selection on critical parameters such as inlet air temperature in drying and product temperature in top spray granulation
- Recipe storage for auto operation
- System provides Alarm Log

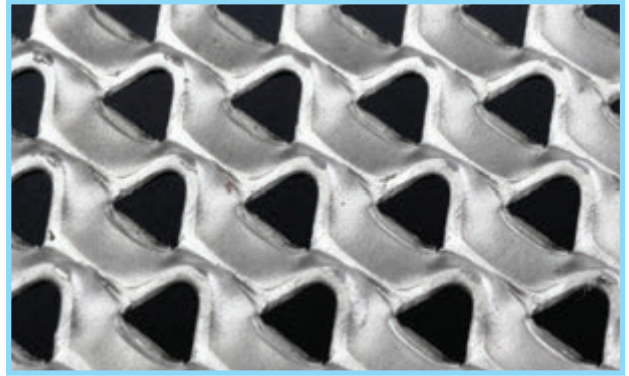

Conidur Mesh for Vortex fluidisation



Inline Sampling Assembly

Level of Instrumentation:

Type of control	Purpose	Operation range	Desired Least Count	Extent of Instrumentation			
				Indication	Alarm	Control	Printing
Temperature	Inlet	0°C to 100°C	0.1°C	Y	Y	Y	Y
Temperature	Exhaust duct	0°C to 100°C	0.1°C	Y	Y	Y	Y
Temperature	Product bed	0°C to 100°C	0.1°C	Y	Y	N	Y
Humidity	Inlet	0-100%	1 %	Y	Y	Y	Y
Time	Cycle time	On real time basis	1 Sec	Y	Y	Y	Y
Differential Pressure	Across the HEPA filter	**	1mm of WC	Y	Y	N	Y
Differential Pressure	Across the Dry type dust collector	**	1mm of WC	Y	Y	N	Y
Differential Pressure	Across product bowl	**	1mm of WC	Y	Y	Y	Y
Differential Pressure	Across Bag filter	(Vendor to recommend)	1CFM	Y	Y	Y	Y

Features:

- Control System compliant to GAMP 4/5 and 21 CFR Part 11
- 5 distinct levels for operation of control system
- Alarm for interlocks and process abnormalities integrated with system, with acknowledgement for respective alarms by operating personal
- Manual back-up system in case of PLC failure
- Specially designed Conidur mesh for mechanism of Vortex formation ensuring uniform core drying
- Twin shaking finger bag system (European make) to assist continuous fluidization and spraying
- Option of providing SS multilayers sintered filter with integrated air cleaning mechanism
- All filters provided with DP gauges with Integration with HMI for HEPA, Fine filter, Product container and Finger bag
- Inlet / Exhaust Location with several alternatives to suit individual customer requirements
- Specially designed explosion flaps
- Inflatable Silicon Seals used in the system
- 2 Pneumatic Cylinders - For Bag Up and Down movement and for Impact Bag Shaking
- Sampling provision of inline analysis of granulation profile such as moisture content and particle size analysis



FBE Bowl with Trolley

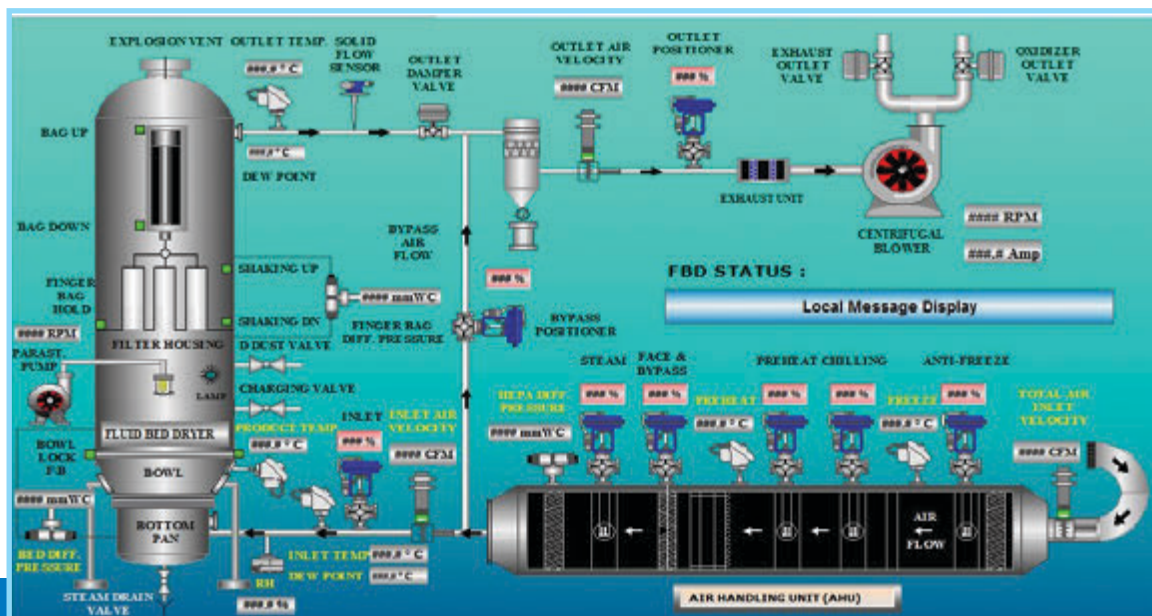

Mimic Display for Process Monitoring and Control

Features:

- Fully automated system for quality by design to correlate statistically
- Specially designed system for light sensitive products
- View port in filter housing and in expansion area of machine tower and product container
- Unique wiring schematics and position numbers for devices
- Inlet and exhaust system provided with a Quick acting safety valves (optional) valve to isolate the supporting ductwork and ancillary equipment should a deflagration in the machine tower occur
- Tri level filtration in Inlet AHU using 10 micron for Pre Air filtration, 3 micron for Secondary Air filtration and 0.3 micron for Final Air filtration using HEPA (99.997 efficiency)
- Humidification and dehumidification system to enable better control on RH (5% to 80%)
- Double skinned SS 304 AHU with a built in Face and --By Pass damper for $\pm 1\sigma$ Temperature control
- Specially designed anti-static anti sparking blower
- High static high efficiency FLP blower installed
- Completely Tool less AHU
- Broken bag detector system to indicate broken bag fault with a provision for adjustable sensitivity
- Filter bag unit with rapid doping control to avoid the personnel injury during the assembling and disassembling of filters
- Food grade gaskets with test certificates
- CE Certified
- In-house pressure tested 2 Bar FBE



Finger Bags with Built-in Safety

Benefits For You:

- 'State of Art' FBD with all latest features
- Easy operations
- Faster and uniform drying
- Easy maintenance
- Overcomes typical problems associated with drying, such as, Improper drying, Fine generation, Excessive drying time
- High quality and better shelf life of the product

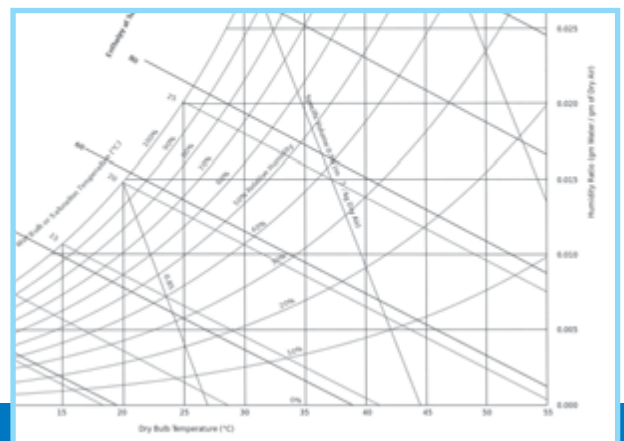

Real Time Process Monitoring through IPC

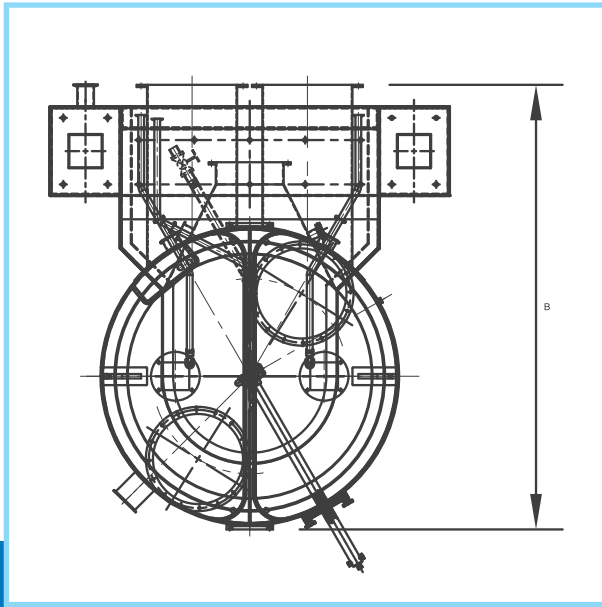

Plan view

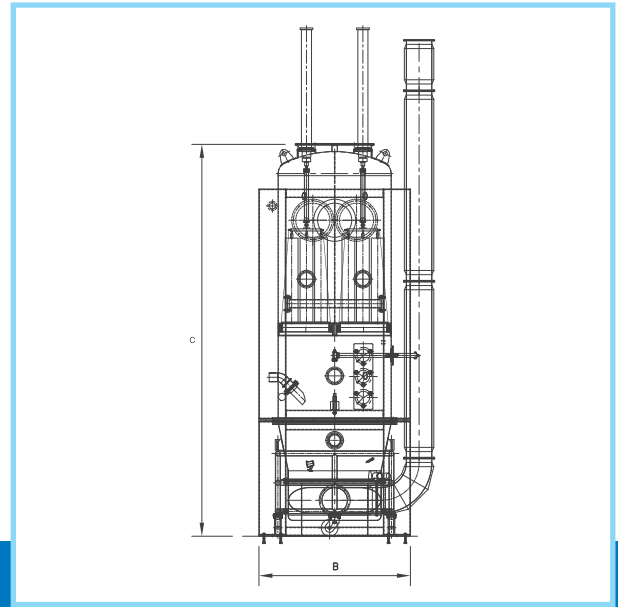

Elevation view

Technical Specifications:

MODEL	WORKING CAPACITY (in Liters)	OVERALL DIMENSIONS (in mm)			MOTOR HP	BLOWER (in CFM)	APPROX. WEIGHT (in kg)
		Length	Width	Height			
TAP-FBE-MINI (Lab Scale modular)	4	860	1940	2200	6		200
TAP-FBE-10 (Lab Scale modular)	8	1200	2000	2500	7.5	600	500
TAP-FBE-25	20	1000	1200	2300		600	1000
TAP-FBE-75	60	1200	1200	3200	15	900	1500
TAP-FBE-100	80	1200	1350	3200	15	1200	1700
TAP-FBE-150	120	1200	1350	3800	20	1200	2000
TAP-FBE-200	160	1400	1550	3800	25	2000	2300
TAP-FBE-250	200	1400	1550	3800	25	2000	2500
TAP-FBE-300	240	2200	1550	3800	30	2000	2500
TAP-FBE-400	320	2700	1760	4300	30	2500	3000
TAP-FBE-600	480	3100	1800	5500	50	3500	3500
TAP-FBE-800	640	3100	2000	5500	50	4500	3500
TAP-FBE-1000	800	3100	2100	5500	50	4500	4000
TAP-FBE-1200	960	3100	2500	7000	75	5000	4300
TAP-FBE-1400	1120	3100	2500	7000	75	5000	4500
TAP-FBE-1800	1360	3400	2600	7500	100	6000	4800

TAP-FBE models are provided with Drying and Top spray processing
 TAP-FBP models are available with bottom spray Wurster processing

OEB5 compliant containment models from our SHIELD 5 Series are available
 12 Bar Explosion proof models from our SHIELD 12 Series are available

Fluid Bed Equipment used in Industries:

- Pharmaceutical
- Nutraceutical
- Food
- Chemical
- Cosmetics

TRAY DRYER

The Tray Dryer from Tapasya assures you of rapid, high-quality and convenient drying technology, with the added Edge of cGMP feature, viz., rounded contours in all internal surfaces. Our multi-capacity tray dryers find wide applications in Pharmaceutical, Nutraceutical, Food, Chemical, Cosmetic & other allied industries.



Features:

- Covered drives
- Two tier trolley with SS Rollers
- Advanced Controls
- Improved design with double door provision
- Enhanced performance by total insulation
- HEPA Filtered Inlet Air
- Rounded corners and angles
- Easy accessibility of internals for Hygienic cleaning
- Even thermal distribution internally all over the chamber with a variation of just $\pm 2^{\circ}\text{c}$

Benefits For You:

- Designed for easy operations
- Faster drying
- Easy maintenance
- Easy Hygiene maintenance
- High quality and better shelf life of the product



Tray Dryer Chamber



Functional Assembly



Recipe Management



Tray Trolley

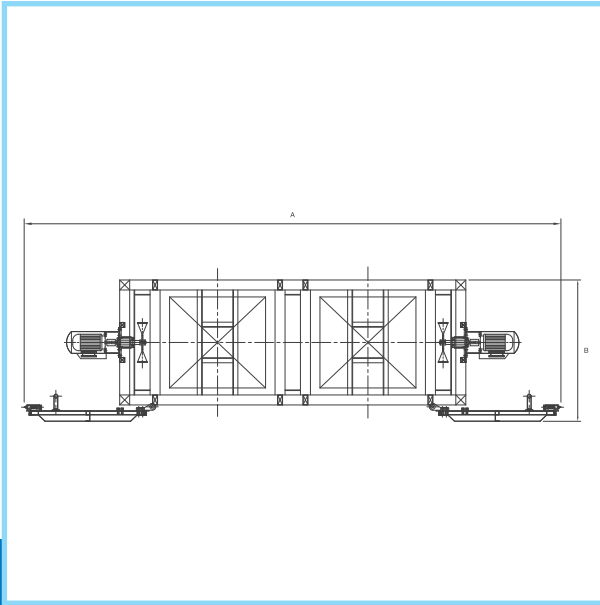

Plan view

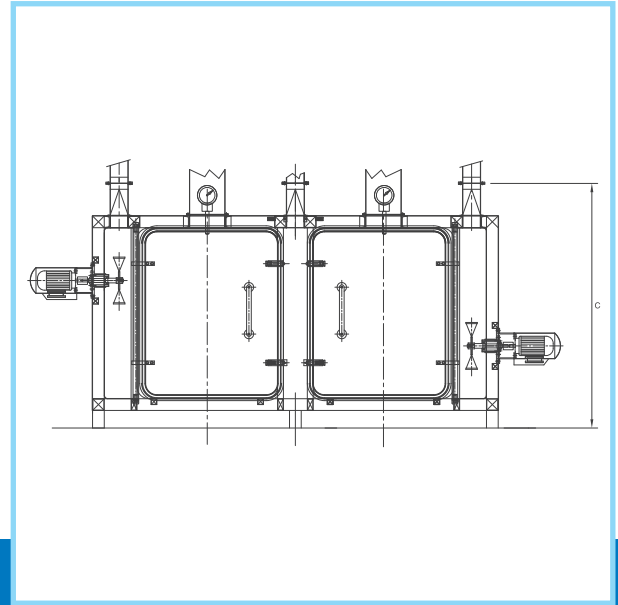

Elevation view

Technical Specifications:

MODEL	No. of trays	WORKING CAPACITY (in Liters)	OVERALL DIMENSIONS (in mm)			MOTOR HP	APPROX. WEIGHT (in kg)
			Length	Width	Height		
TAP-TD-6	6	24	540	1300	9500	1	80
TAP-TD-12	12	48	950	1300	950	2	120
TAP-TD-24	24	96	1600	2000	2000	3	200
TAP-TD-48	48	192	2550	2000	2600	5	350
TAP-TD-72	72	288	1450	4000	2900	8	430
TAP-TD-96	96	384	1450	4000	2900	8	500

Customised sizes available on request

Tray Dryer used in Industries:

- Pharmaceutical
- Nutraceutical
- Food
- Chemical
- Cosmetics

ROTO CONE VACUUM DRYER

The improved technology in Tapasya's Roto Cone Vacuum Dryer integrates drying operation under vacuum. It facilitates enhanced drying efficiency for heat labile or heat sensitive products, low temperature operation and economy of process by total solvent recovery. It also helps cGMP - based working by achieving optimum dust control, while offering the advantage of efficient charging and discharging of material. The dryer is also available with an optional thermal medium system and is ideal for meeting the drying needs across various industries such as API, chemical, Food etc.



Features:

- Total cGMP finish construction
- All contact parts in SS 316L
- Jacket fabrication to accept varied heating sources
- Optimum and continuous vacuum maintenance during processing
- Working cone totally leak proof during operation
- Easy loading with quick discharge
- Uniform Material shuffling over the heated contact surface of cone
- Suitable size condensers and receivers for solvent collection
- Preventive controls on Energy heads to maintain operational efficiency
- Mechanical seals for vacuum and heating sides
- Vacuum / Gravity & Bin loading system for Minimal Material handling
- Can be offered in Nickel, Hastalloy, Titanium and Tantalum
- All rotating parts are provided with - SS Guards for Operator Safety
- Interlocking with Drive through Proximity Switch



RCVD with Chopper Integration



SS316L Sintered Filter Vacuum Nossel



Hermetically Sealed Top Lid

Benefits For You:

- Enhanced drying operation
- Total solvent recovery
- Economy of process
- cGMP compliant process
- Varied drying applications



Control Parameter Pharma cGMP Application

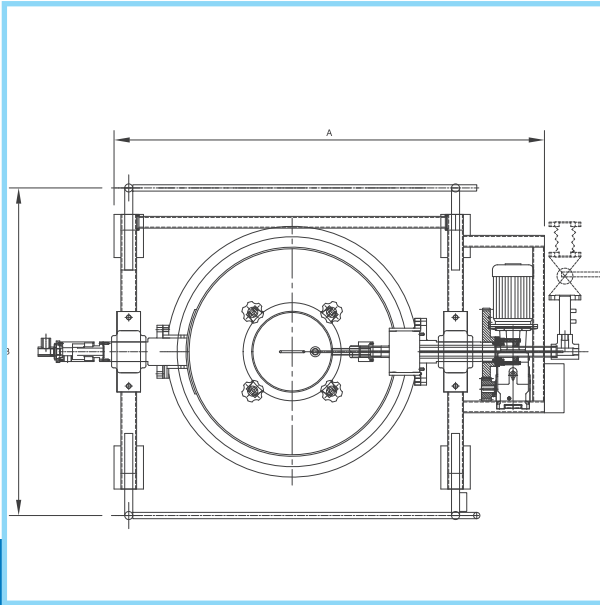

Plan view

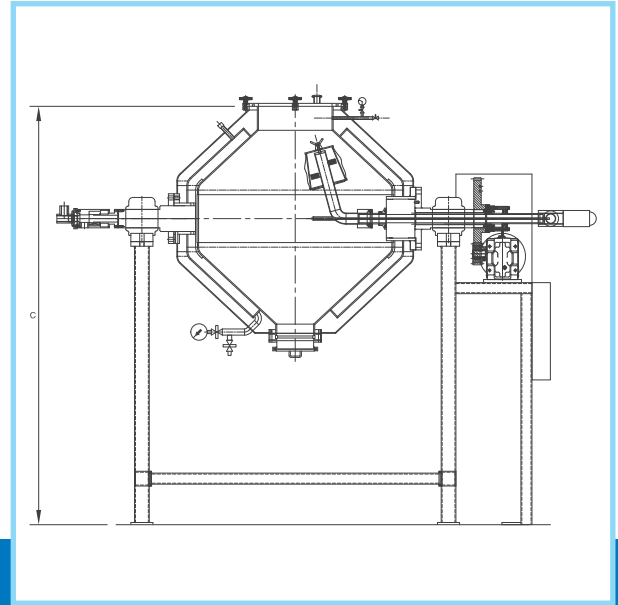

Elevation view

Technical Specifications:

MODEL	WORKING CAPACITY (in Liters)	OVERALL DIMENSIONS (in mm)			MOTOR HP	APPROX. WEIGHT (in kg)
		Length	Width	Height		
TAP-RCVD-25	15	3750	1800	1820	2	500
TAP-RCVD-50	30	3830	1800	2400	2	600
TAP-RCVD-100	60	1100	1200	1600	3	800
TAP-RCVD-300	180	1400	1400	2100	3	1600
TAP-RCVD-500	300	1700	1600	2500	5	2000
TAP-RCVD-750	450	2300	1800	2900	5	2300
TAP-RCVD-1000	600	2600	1800	3100	7.5	2500
TAP-RCVD-2000	1200	3000	2000	3400	10	3500
TAP-RCVD-3000	1800	3350	2500	3900	12	4000
TAP-RCVD-5000	3000	4200	2600	3700	15	5500
TAP-RCVD-10000	6000	4500	2800	4500	25	6500

Customised sizes available on request

Roto Cone Vacuum Dryer used in Industries:

- Pharmaceutical
- Nutraceutical
- Food
- Chemical
- Cosmetics

MILLING

Milling is the mechanical process of reducing the particle size of solids.
Mechanism involved are cutting, attrition, impact and pressure.
Uniform particle size results in better compressibility and dissolution rate.

TAP CONE MILL	30
UNDER DRIVEN CONE MILL	33
MULTI MILL	36
SIFTER CUM MULTI MILL	39
OSCILLATING GRANULATOR	42
VIBRATORY SIFTER	45
DELUMPER	48

TAP CONE MILL

Tapasya's Tap Cone Mill is used for High Speed Shredding, Sizing, and Grinding of Powders, Granules, Tablets and a wide range of wet and dry materials, without special attachments. As compared to the four common principles of size reduction i.e. cutting, attrition, impact and pressure, which often do not produce controlled size reduction, this machine utilises the principle of Centrifugal Shearing force. It has wide applications in the Pharmaceutical and Nutraceutical industry for shredding of rejected tablets, Dry Milling, Wet Milling, Shredding of oversized material (De lumping), etc.



Features:

- Material of construction SS 316L
- Compact size online model also available
- Imported Laser Driller Mesh for Dry application
- Safety Standards with no outside cables
- Vacuum Loading option
- Bin charging Loading system option
- Dust free closed system for charging and discharging of powders or granules
- Easy to clean
- Minimum maintenance
- Different profile of blade and sieve available



Sanitary Process Chamber Design



Special Design Sieve for Efficient Milling

Benefits For You:

- High speed shredding, sizing & grinding
- High safety standards
- Dust-free closed system
- Minimal maintenance
- Varied applications



Cover Hopper



Toolless Assembly

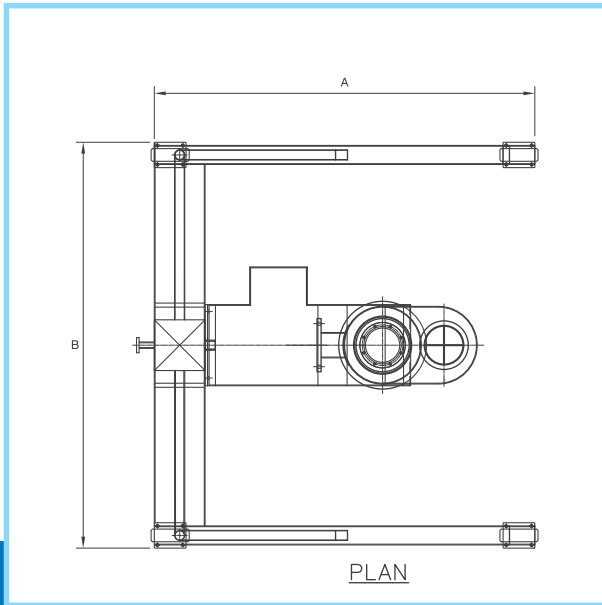

Plan view

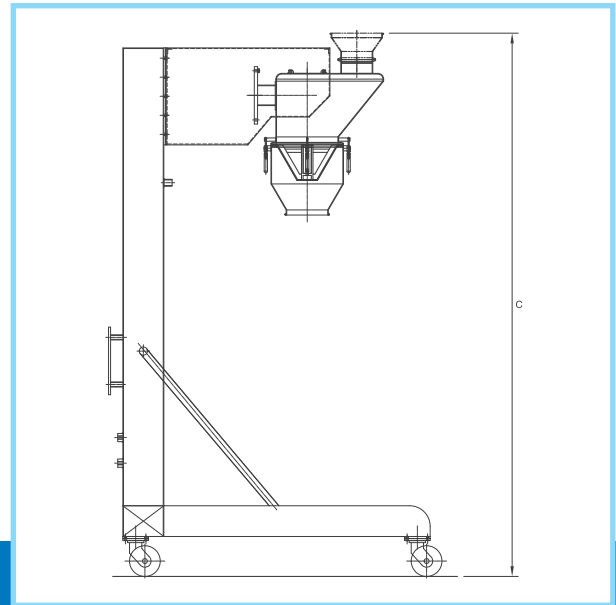

Elevation view

Technical Specifications:

MODEL	WORKING CAPACITY (in Kg/Hr)	OVERALL DIMENSIONS (in mm)			MOTOR HP	APPROX. WEIGHT (in kg)
		Length	Width	Height		
TAP-TCM-20	20	910	700	1750	1.5	150
TAP-TCM-50	50	910	700	1750	1.5	150
TAP-TCM-250	250	1700	1600	2200	5	400
TAP-TCM-500	500	1700	1900	3200	5	600

OEB5 compliant containment models from our **SHIELD 5** Series are available
12 Bar Explosion proof models from our **SHIELD 12** Series are available

Customised sizes available on request

Tap Cone Mill used in Industries:

- Pharmaceutical
- Nutraceutical

UNDER DRIVEN CONE MILL

Tapasya's Under Driven Cone Mill meets all your requirements for achieving uniform size reduction, sieving, de-agglomeration, dispersion and mixing of dry and wet products, with optimum process efficiency and product consistency. It offers all the benefits of Tapasya's underdriven Cone mill with additional advantages including inline integration and can be used in multiple industries for higher outputs.



Features:

- Uses Centrifugal force for both Milling and Sifting
- Gentle grinding action with close particle size distribution
- Minimal fines generation
- Charging of material- either gravity fed or vacuum transferred
- Increased throughput with 50% more capacity than conventional mills
- Adaptable & flexible design with interchangeable Cone mill and Rotary sifter and through the wall design
- Customised options for feeding and handling
- Readily available scale up from lab to production scale
- Material of construction : SS 316 / SS 316L / Food grade materials
- Easy to clean

Benefits For You:

- High efficiency
- Multi-purpose utility as Cone mill or Rotary sifter
- Uniform sized output
- Suitable for milling dry, wet, fatty or sticky materials
- Low heat generation, low noise and low dust levels
- Easy maintenance
- Versatile application in varied industries

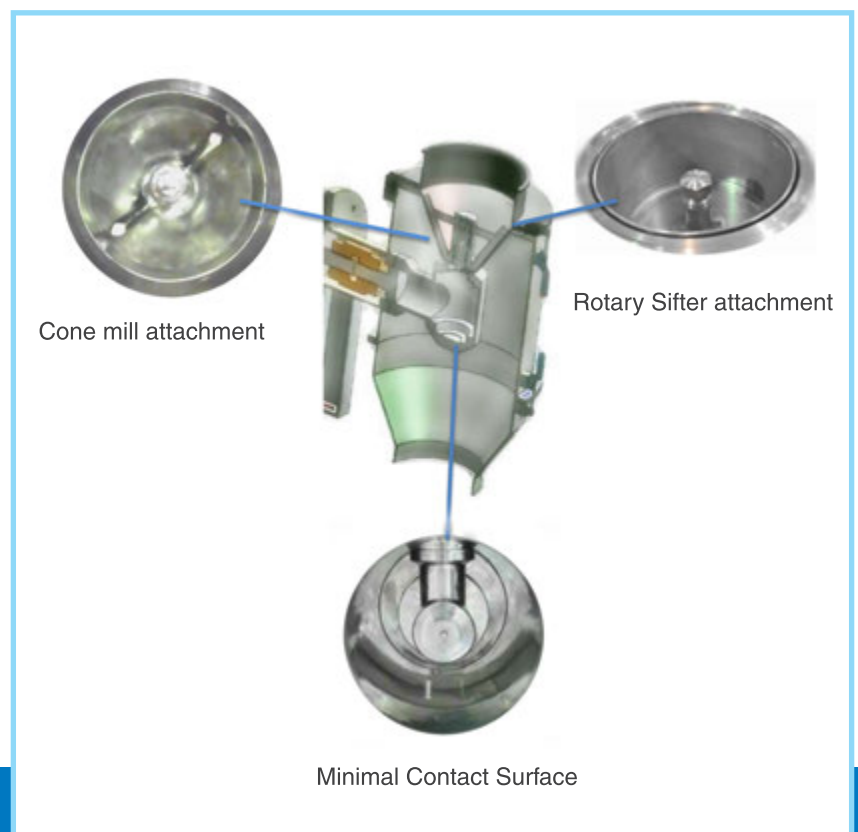

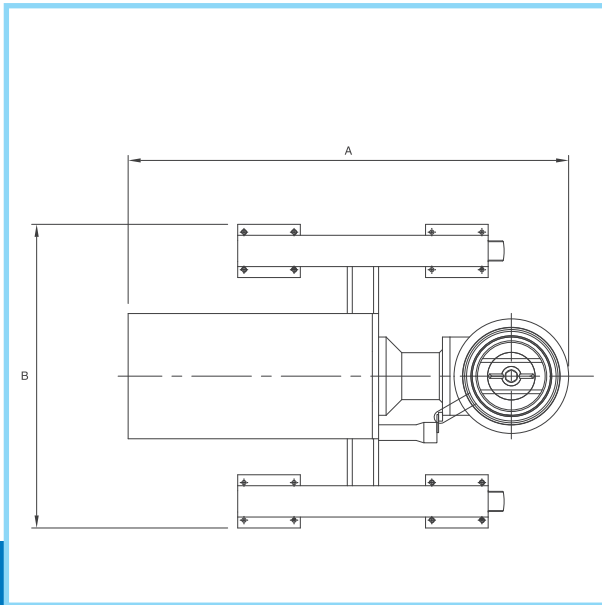

Plan view

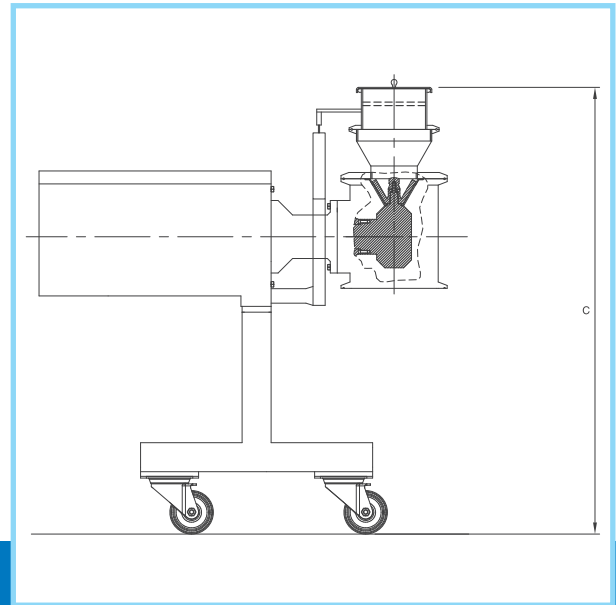

Elevation view

Technical Specifications:

MODEL	WORKING CAPACITY (in kg/hr)	OVERALL DIMENSIONS (in mm)			MOTOR HP	APPROX. WEIGHT (in kg)
		Length	Width	Height		
TAP-UDCM-100	100	500	800	800	0.5	400
TAP-UDCM-250	250	550	900	900	5	600
TAP-UDCM-500	500	750	1000	1500	5	800
TAP-UDCM-1000	1000	900	1100	1550	5	1000
TAP-UDCM-2000	2000	1000	1500	1800	7.5	1200
TAP-UDCM-5000	5000	1200	1700	1900	10	1600

OEB5 compliant containment models from our **SHIELD 5** Series are available
12 Bar Explosion proof models from our **SHIELD 12** Series are available

Customised sizes available on request

Under Driven Cone Mill used in Industries:

- Pharmaceutical
- Nutraceutical
- Food
- Chemical
- Cosmetics

MULTI MILL

Tapasya's Multi-mill is ideal for high speed Granulating, Pulverising, Mixing, Shredding and Chopping of a wide range of wet and dry materials without special attachments. This machine utilises the principle of variable force swing hammer blades, having both knife and impact edges, rotating with a carefully selected screen to control size reduction. The product enjoys wide applications in the Chemicals, Pharmaceuticals, dyestuff, colours, ceramics, food products, cosmetics, pesticides, fertilizers, plastics, spices, bakeries, resins, insecticide and other industries.



Features:

- Efficient Dust contained Multi mill
- Machine Portable on Castor wheels
- High output with Process uniformity
- All contact parts are in SS 316L
- Direction of the Blade rotation can be changed using a Reversing switch for Hammer or Knife operation for various product type
- Multiple combinations of Screens / Speeds / Number of Blades available for every Product type
- Higher Screen opening area for Higher Throughput
- Easy Dismantling and Cleaning of all Components reducing Production Downtime and increasing Productivity
- Additional perforated screen at the bottom of pulverising chamber ensuring Higher Fineness and Controlled Size of Granules
- Built in Variable Frequency Drive for multiple speeds

Benefits For You:

- High speed operations
- Minimal material handling
- Dust-free operations
- Easy to handle
- Higher throughput
- Easy maintenance



Knife and Hammer Blade Design



Multi Mill Mobile Model

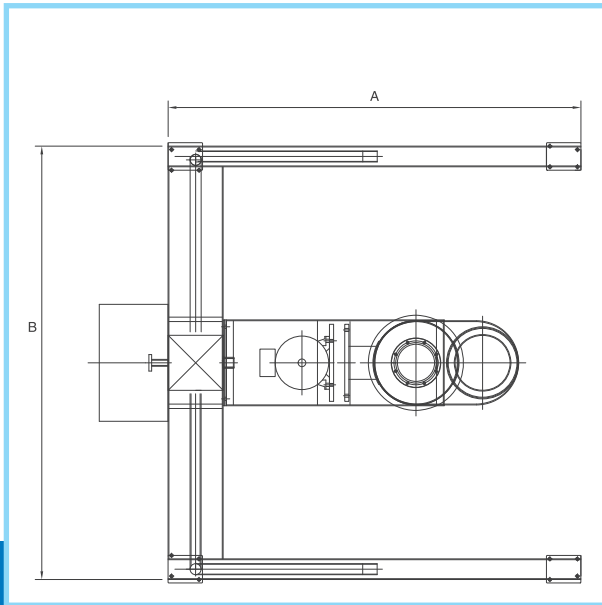

Plan view

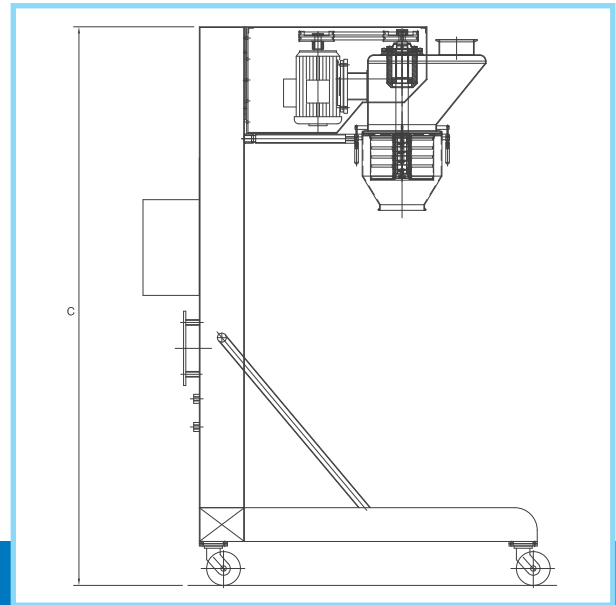

Elevation view

Technical Specifications:

MODEL	WORKING CAPACITY (in Kg/Hr)	OVERALL DIMENSIONS (in mm)			MOTOR HP	APPROX. WEIGHT (in kg)
		Length	Width	Height		
TAP-MM-20	20	910	700	1750	1.5	150
TAP-MM-50	50	910	700	1750	1.5	150
TAP-MM-250	250	1700	1600	2200	5	400
TAP-MM-500	500	1700	1900	3200	5	600

OEB5 compliant containment models from our **SHIELD 5** Series are available
12 Bar Explosion proof models from our **SHIELD 12** Series are available

Customised sizes available on request

Multi Mill used in Industries:

- Pharmaceutical
- Nutraceutical

SIFTER CUM MULTI MILL

Tapasya's Uni-Granulator is a revolutionary granule sifting cum milling system, that redefines traditional granule or powder sifting process.

It ensures uniform sizing of dried granules and enables processing with negligible product loss.



Features:

- High productivity with an output capacity of 4 to 10 Kgs / minute
- Portable and compact design, mounted on a sturdy SS frame
- Sieve drums available in 4 to 40 mesh sizes
- Continuous Feed and Product discharge for Dust free transfer
- Vibration free and Soundless design
- Tool less design for easy handling
- Meets latest cGMP Standards
- Easy Dismantling, Cleaning and Reassembling within 10 to 15 min
- Turbo Sifter with 10 bar compliance for specialised process available

Benefits For You:

- Assured Output of Granules of Uniform size
- High output
- Easy to handle
- Easy Maintenance
- Dust-free operations that meet cGMP requirements
- Advanced design with no vibration and noiseless



Knife and Hammer Blade



Quick Assembly and Disassembly

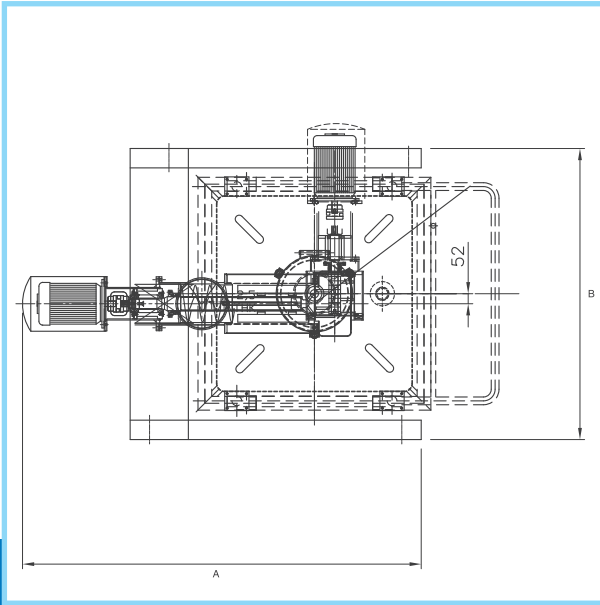

Plan view

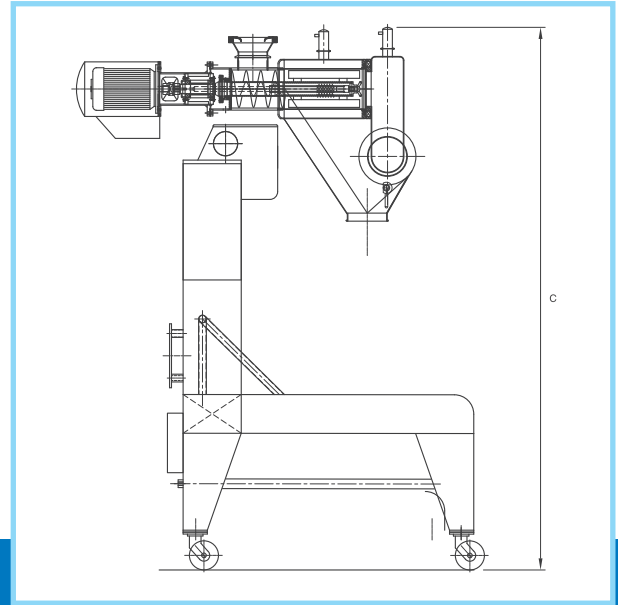

Elevation view

Technical Specifications:

MODEL	WORKING CAPACITY (in Kg/hr)	OVERALL DIMENSIONS (in mm)			MOTOR HP	APPROX. WEIGHT (in kg)
		Length	Width	Height		
TAP-SCMM-250	250	1700	1600	2200	5	400
TAP-SCMM-500	500	1200	1900	2150	5	600

12 Bar Explosion proof models from our **SHIELD 12** Series are available

Customised sizes available on request

Sifter Cum Multi Mill used in Industries:

- Pharmaceutical
- Nutraceutical

OSCILLATING GRANULATOR

Tapasya's Oscillating Granulator is ideal for meeting the multiple needs of Dry Granulation, Wet Granulation, Screening, Crushing, Breaking lumps, etc for the Pharmaceutical and Nutraceutical industry. The oscillating motion of the rotor with uniform speed and force applied to the material, improves the granulating process and enhances the compressibility of the product.



Features:

- Oscillating rotor with back and forth motion for even distribution of material
- SS construction (AISI 316 / 316L)
- Inside polished Ra = 0.8 micron, outside ground (grain 220)
- Maintenance free design, GMP execution
- Multiple varieties of sieves, fine sieves & perforated plates available to suit all your needs
- Range 0.5 mm to 10 mm
- Robust, Simple & Compact Design
- Easy Installation in Production Line
- Low noise level as per international norms
- Easy for Cleaning



cGMP Construction in SS316L

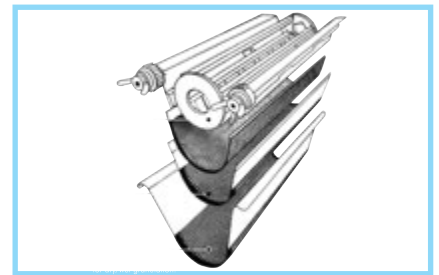

Perforated Sieve for Dry / Wet Granulation

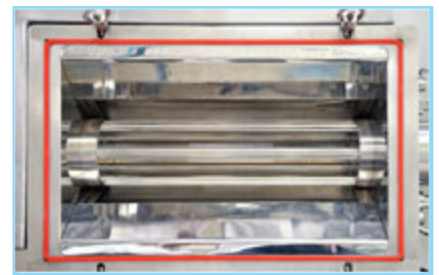

Nibbling Blades for Gentle Granulation

Benefits For You:

- High output with uniform sized granules and less fines
- Easy maintenance



Automated Control System

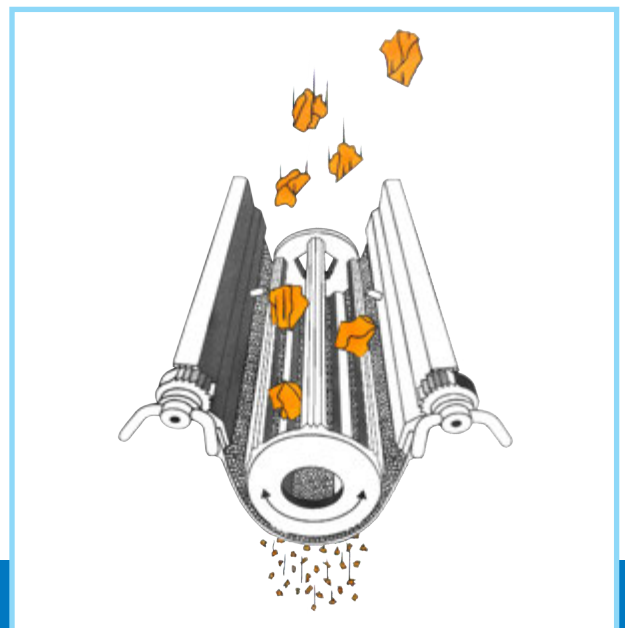

Precision Design for Uniform Granules and Less Fines

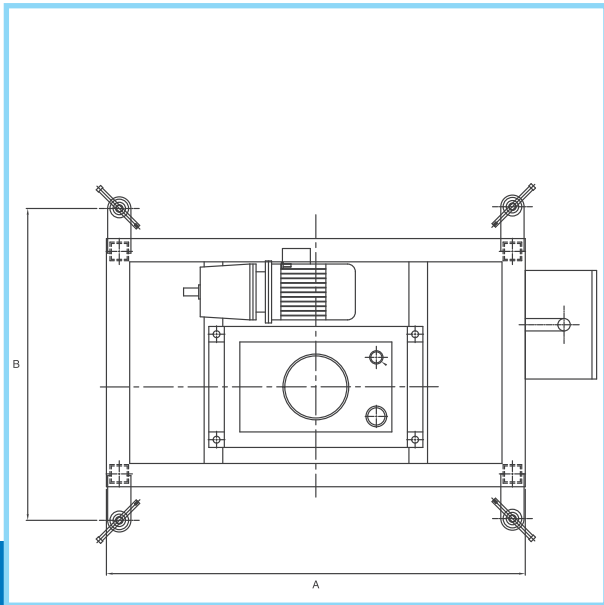

Plan view

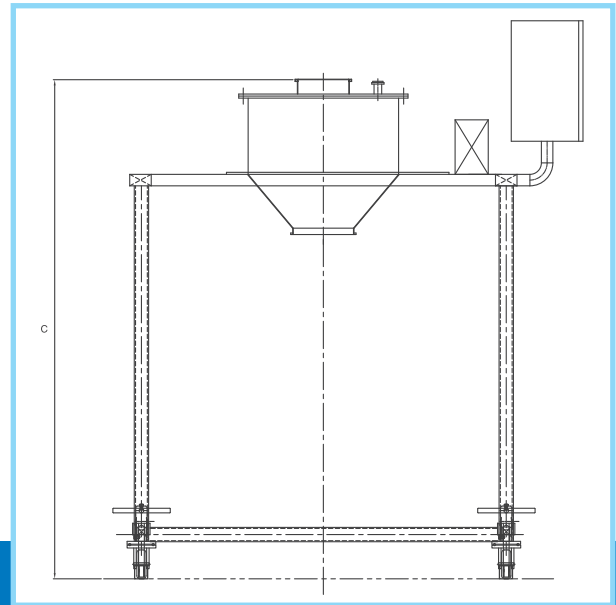

Elevation view

Technical Specifications:

MODEL	WORKING CAPACITY (in Kg/Hr)	OVERALL DIMENSIONS (in mm)			MOTOR HP	APPROX. WEIGHT (in kg)
		Length	Width	Height		
TAP-OG-250	250	1250	1600	1600	3	600
TAP-OG-500	500	1250	1600	1800	5	900

Customised sizes available on request

Oscillating Granulator used in Industries:

- Pharmaceutical
- Nutraceutical

VIBRATORY SIFTER

Based on the 'Gyro' principle, Tapasya's Vibratory Sifter meets the requirements of 'Dust-free Sifting' of the Pharmaceutical, Nutraceutical, Food, Chemical, Cosmetic and other allied industries. The complete vibrating assembly has a specially designed gyro motor that is fitted with top & bottom eccentric weights designed as per required centrifugal force. The sifter is designed for convenient usage & maintenance.



Features:

- cGMP Model with contact parts in SS 316 & Non-Contact Parts in SS 304
- Amplitude of Vibratory Motion adjustable
- SS 316 Hood with 200 mm dia Nozzle for dust free charging of Powders
- Easy dismantling, cleaning & assembling through quick opening SS 316 clamps
- Portable mounted on sturdy Castor Wheels
- Vibrating assembly isolated by rugged springs
- Dust-free design
- Independent Jacks for lifting the machine off the floor for effective sifting
- Silicon Bonded Integrated Mesh and Silicon Balls for Lump Breaking & Mechanical cleaning
- Provision for advanced Ultrasonic mesh cleaning attachment
- CE Certified

Benefits For You:

- Dust-free sifting
- Design compliant with cGMP requirements
- Easy to handle
- Multiple mesh size available to suit your individual processing needs



Antistatic Mesh



Food Grade Gasket for Dust Free Charging



Eccentric Motor for Controlled Vibration

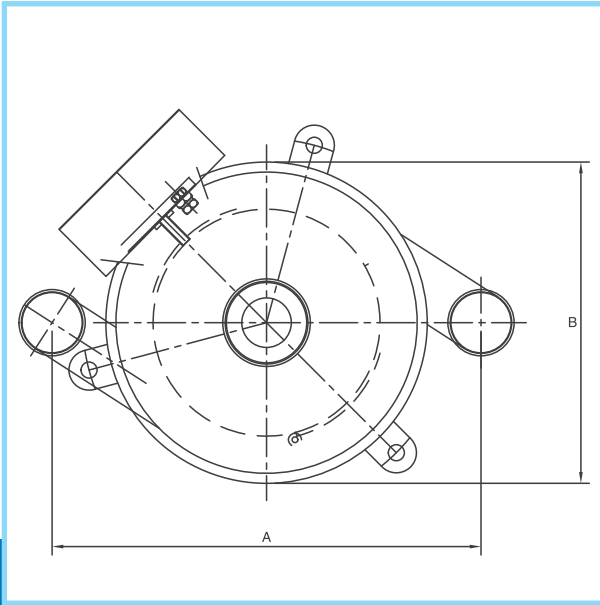

Plan view

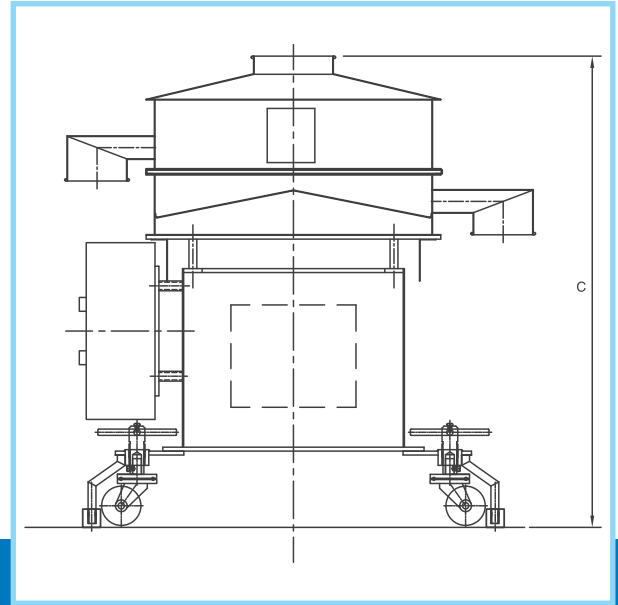

Elevation view

Technical Specifications:

MODEL	OVERALL DIMENSIONS (in mm)			MOTOR HP	APPROX. WEIGHT (in kg)
	Length	Width	Height		
TAP-VS-12	400	400	1000	0.25	50
TAP-VS-24	700	700	1000	0.25	80
TAP-VS-30	850	850	1250	0.5	120
TAP-VS-36	1000	1000	1600	0.5	150
TAP-VS-48	1300	1300	1850	1	180
TAP-VS-60	1600	1600	2000	1.5	220
TAP-VS-72	1800	1800	2200	2	260

Customised sizes available on request
Laboratory model design available

Vibratory Sifter used in Industries:

- Pharmaceutical
- Nutraceutical
- Food
- Chemical
- Cosmetics

DELUMPER

Tapasya's Delumper is designed to handle through processing applications in varied industries including, chemical, plastics, food, nutraceuticals and pharmaceutical industry. It is a versatile size reduction equipment suitable for wet, dry, hard, soft, resinous, brittle or sticky material that renders them free flowing.



Features:

- Cost effective, rapid de-agglomeration for varied industries
- Ultra sanitary design for Pharmaceutical and Nutraceutical applications
- Handles homogeneous or heterogeneous materials, dry powders, resinous, hard or soft agglomerates without degrading the product or overheating the product or producing fines
- Powerful crushing capabilities, with option of increasing shaft length and number of blades
- Engineered to fit into open or close systems
- Material loading by gravity or integrated with vacuum transfer line for cost efficient high throughput
- Specially designed delumper blades driven using cantilevered drive to execute positive once-through chopping action
- Eliminates blockages in further processing of material.
- Easy cleaning & maintenance
- Highly polished surfaces
- cGMP compliant design
- Can be installed on a platform or mobile structure

Benefits For You:

- Enables cost-effective, rapid de-agglomeration of variety of material
- Easy maintenance
- cGMP compliant



Breaker Blades on Rotating Shaft

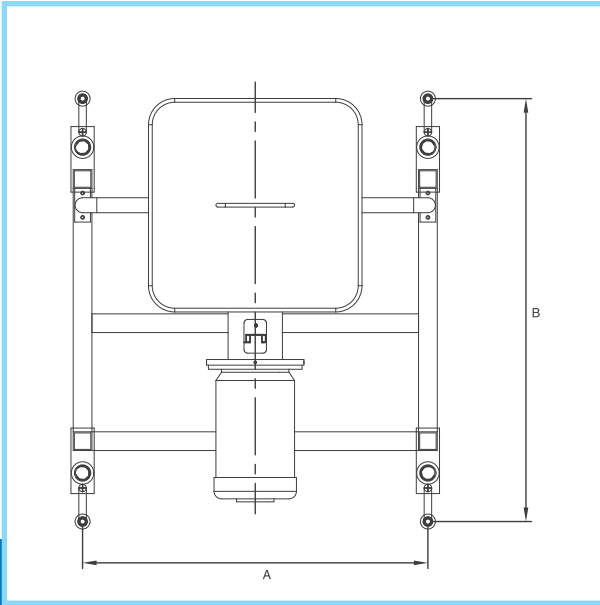

Plan view

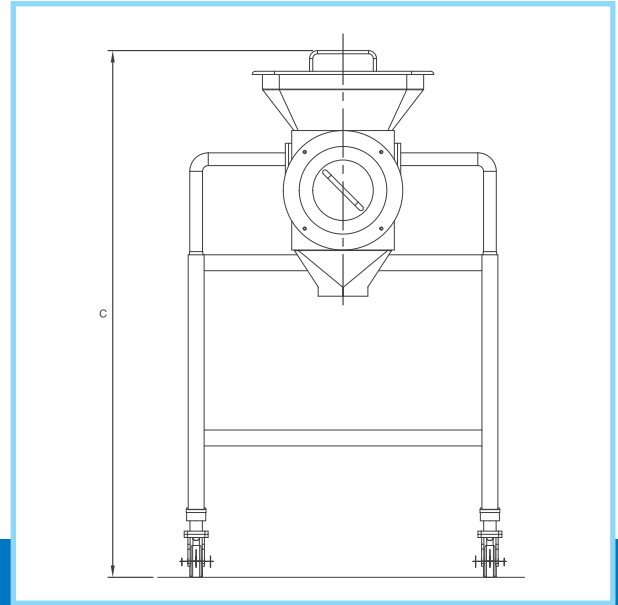

Elevation view

Technical Specifications:

MODEL	WORKING CAPACITY (in Kg/Hr)	OVERALL DIMENSIONS (in mm)			MOTOR HP	APPROX. WEIGHT (in kg)
		Length	Width	Height		
TAP-DL-250	250	1000	1600	1600	3	600
TAP-DL-500	500	1250	1600	1800	5	900

Customised sizes available on request

Delumper used in Industries:

- Pharmaceutical
- Nutraceutical
- Food
- Chemical

BLENDING

It has been generally accepted that solids mixing proceeds by a combination of one or more mechanisms.

A) Convective mixing **B)** Shear Mixing **C)** Diffusive mixing

Blend Uniformity in Critical processes like Dry mixing or intra and extra granular blending can be achieved for even distribution and superior compressibility.

'V' BLENDER _____ **52**

CONTA BLENDER _____ **55**

OCTAGONAL BLENDER _____ **58**

DOUBLE CONE BLENDER _____ **61**

RIBBON BLENDER _____ **64**

PLOUGH SHEAR MIXER _____ **67**

'V' BLENDER

Tapasya's 'V' Blender is an intensive mixing system designed specially to handle ordered dry mixing of excipients such as cohesive as well as adhesive powder. This rotating shell V-type blender with no packing glands around the shafts entering the chamber ensure total elimination of cross contamination. The special design ensures minimal attrition when blending fragile granules and is suitable for Pharmaceutical, Nutraceutical, Food & Cosmetic industries.

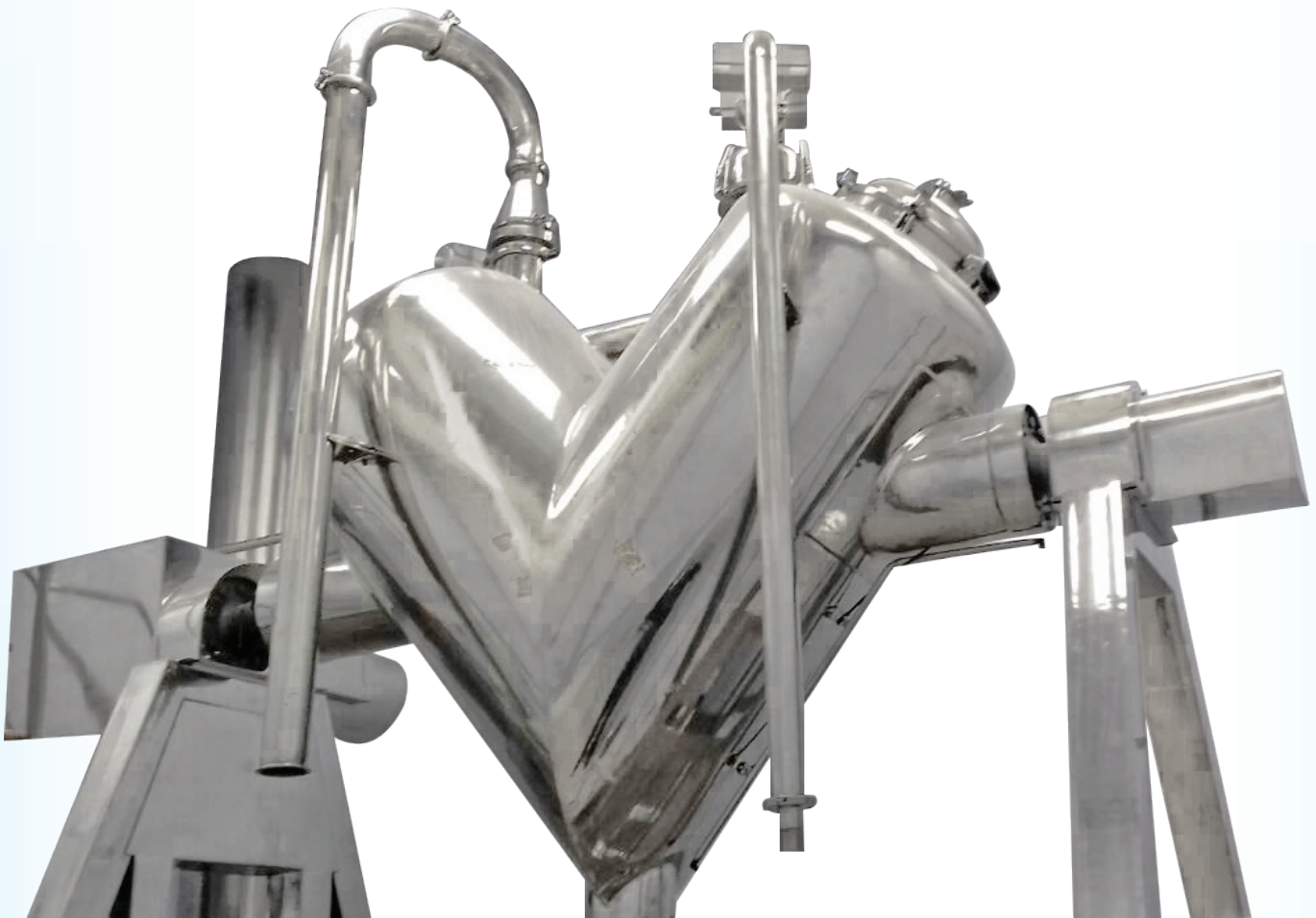

Features:

- Rotating V-Type Shell with large capacity
- Easy loading & unloading
- Special baffles to increase mixing shear
- Integrated Vacuum loading option available
- Material of construction SS 316L
- Wide Capacity options available from 5 -1200L, with custom made capacities upto 10000L
- Intensifier bar for special applications available
- Dust-free operations when combined with Bin charging system
- Near complete discharge of product material
- No shaft projection; hence no product contamination
- Easy to clean with internal attachments like lump breakers and liquid dispensers



'V' Design for Diffusion Blending



Intensifier Bar with Sprinkle Provision

Benefits For You:

- Ideal for blending dry powders and granules, including fragile material
- Designed for dust-free processing, complete discharge of material with no contamination
- Easy to clean
- Minimum maintenance



Cantilever Design



Built in Operator Safety

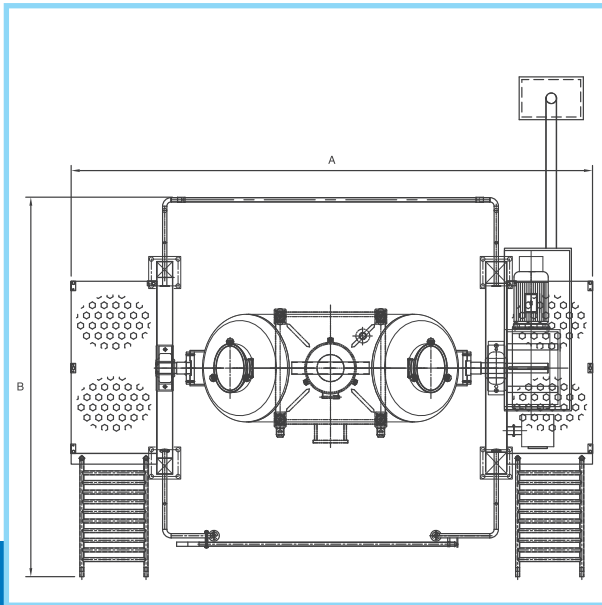

Plan view

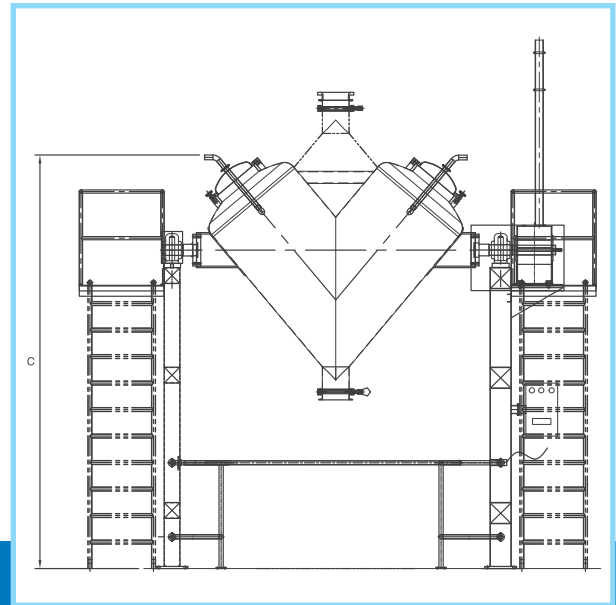

Elevation view

Technical Specifications:

MODEL	WORKING CAPACITY (in Liters)	OVERALL DIMENSIONS (in mm)			MOTOR HP	APPROX. WEIGHT (in kg)
		Length	Width	Height		
TAP-UB-10 (Universal model for Lab Blenders)	Interchangeable bowl upto 7 L working capacity	1280	1150	1550	1.5	500
TAP-UB-20 (Universal model for Lab Blenders)	Interchangeable bowl upto 14 L working capacity	1280	1150	1550	1.5	650
TAP-VB-100	70	1900	1500	3000	3	800
TAP-VB-150	105	1680	1510	2200	3	
TAP-VB-300	210	2200	1050	2500	3	2000
TAP-VB-500	350	2500	1500	3200	5	2600
TAP-VB-1000	700	2900	2700	4300	7.5	3000
TAP-VB-2000	1400	3200	1800	4500	10	4000
TAP-VB-5000	3500	4450	4520	4800	15	5500
TAP-VB-10000	7000	5900	3000	7000	25	7000

Customised sizes available on request

'V' Blender used in Industries:

- Pharmaceutical
- Nutraceutical
- Food

CONTA BLENDER

Developed by Tapasya's Design Team, the Conta Blender represents a major advance that enables dust free transfer of powders and granules from Drying to Compression / Filling equipments with reduced material handling. The unique design ensures rotation in a diagonal axis and in an eccentric plane resulting in a homogeneous blend within a short time. It finds varied applications across multiple industries.



Features:

- Designed for dust free blending and transfer of powders and granules
- 0° stopping for easy docking and undocking of the bin
- Fencing around the cage with an entry point for the bin on detachable trolley
- Limit switch on entry door to prevent accidental operation of the cage
- Flexibility of accepting variable bin sizes providing wide range of batch volumes
- cGMP construction with cladded polished S. S. Sheets
- Containers of Varying size for varying batch size
- Built-in Butterfly valve (150 mm dia) at the bottom for discharge
- Suitable leak proof vent on top



Square Cross Section Conical Bottom Bins

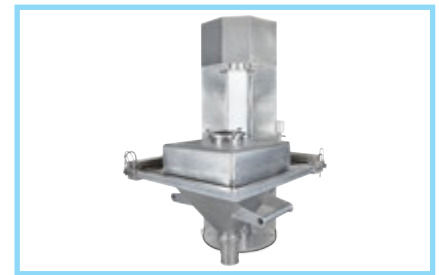

Subdividing Discharge System

Benefits For You:

- Single step transfer from Drying to Compression / Filling equipments
- Superior mixing efficiency
- Reduced material handling
- Highly effective for low volume active blending with as low as 1% active
- Processing of different sizes of production batches with scale up data
- Dust-free operation
- No risk of segregation on extended processing
- No Cleaning down time as the product container is mobile



Holding Arm



Interchangeable Bin Capacity



Eccentric Bin Holding

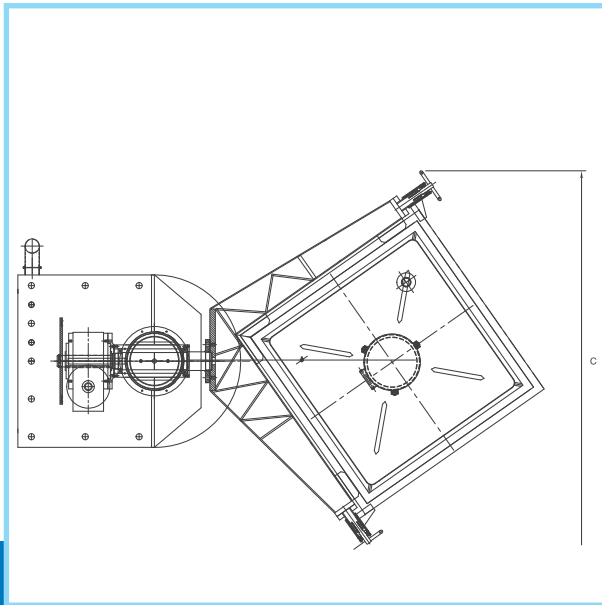

Plan view

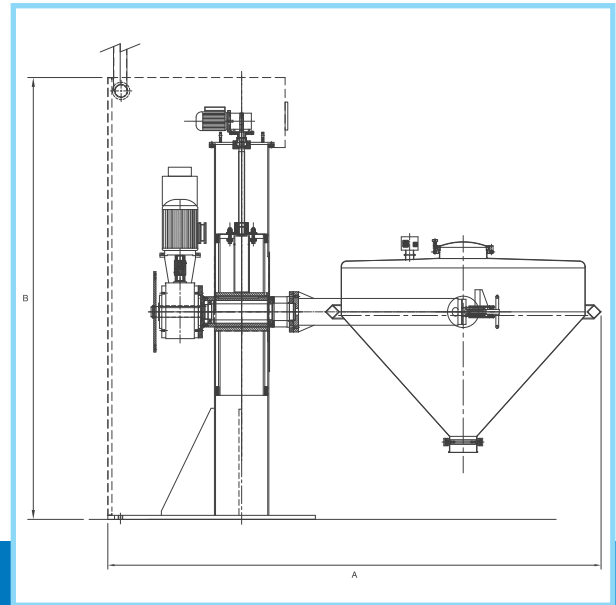

Elevation view

Technical Specifications:

MODEL	WORKING CAPACITY (in Liters)	OVERALL DIMENSIONS (in mm)			MOTOR HP	APPROX. WEIGHT (in kg)
		Length	Width	Height		
TAP-UB-10 (Universal model for Lab Blenders)	Interchangeable bowl upto 7 L working capacity	1280	1150	1550	1.5	500
TAP-UB-20 (Universal model for Lab Blenders)	Interchangeable bowl upto 14 L working capacity	1280	1150	1550	1.5	650
TAP-PB-75	53	2470	800	2000	1.5	700
TAP-PB-100	70	2470	800	2000	3	800
TAP-PB-150	110	2470	800	2000	3	1000
TAP-PB-300	210	2200	1000	2400	3	2000
TAP-PB-500	350	2500	1000	2400	5	2600
TAP-PB-750	530	2510	1000	2400	5	2700
TAP-PB-1000	700	2510	1000	2400	5	2900
TAP-PB-1200	840	3300	1200	4500	7.5	3000
TAP-CB-1500	1050	3200	1800	4500	10	4000
TAP-CB-2000	1400	4450	4520	4800	15	5500
TAP-CB-10000	7000	5900	3000	7000	25	6500

Customised sizes available on request

Conta Blender used in Industries:

- Pharmaceutical ■ Nutraceutical
- Food ■ Chemical
- Cosmetics

OCTAGONAL BLENDER

Tapasya' s Octagonal Blender, the unique octagonal shape is designed to process larger volume of material for efficient angular momentum of the powder to achieve blend uniformity. It is ideal for gentle blending of dry granules or for powder mixing and has wide applications range across many industries. Tapasya has successfully installed over 1800 octagonal blenders world-over.



Features:

- Material handling through Bin charging or Vacuum charging
- Dust free closed system in Bin charging
- Lower Power consumption than other tumble blenders
- Slow speed Blender with Gentle blending of Dry granules and powder
- Maintenance free design
- Rectangular opening Lid with Removable Baffle mounted inside
- Optional in built in Vacuum design with no external PTS required
- Zero Jerk Load as machine is both dynamic and statically balanced
- Baffles are eliminated with blending profile analysis available
- Complete Design engineering along with the Extrapolation data available
- Detailed torque calculation for the Bin loading Model available
- Pneumatically actuated valves for dust free transfers
- Bins with Level sensory for automatic cut off
- Mechanical Seals on shafts for Pneumatic connections
- cGMP design for ease of cleaning
- CE Certified

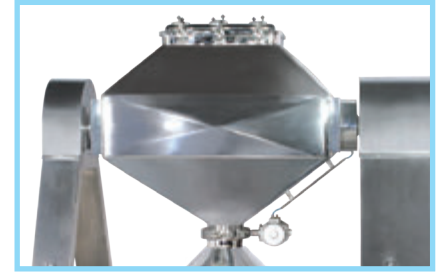

Octagonal Design for
Multifold Action Blending

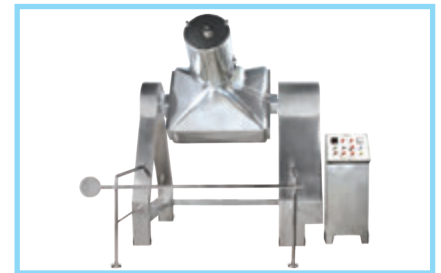

Bin Type Charging

Benefits For You:

- Ideal for all your 'Gentle Blending' needs
- Designed for total dust-free handling
- Maintenance free design
- Occupies less space
- Lower power consumption
- Easy to wash in place with cGMP design
- Documentation support available



Optimum Space Utilization

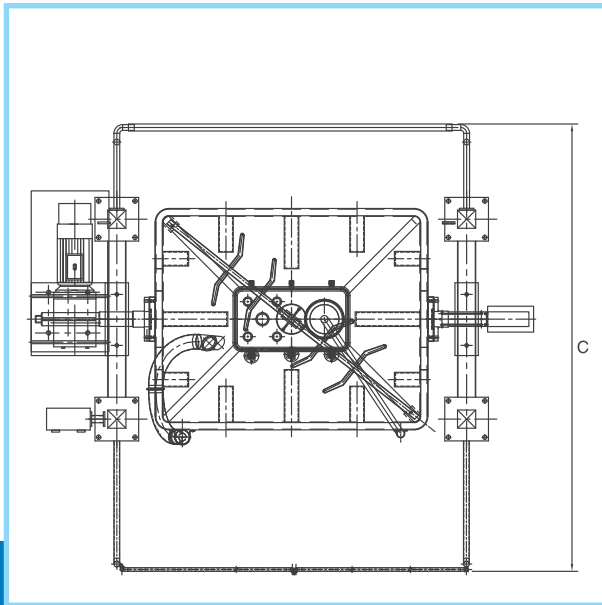

Plan view

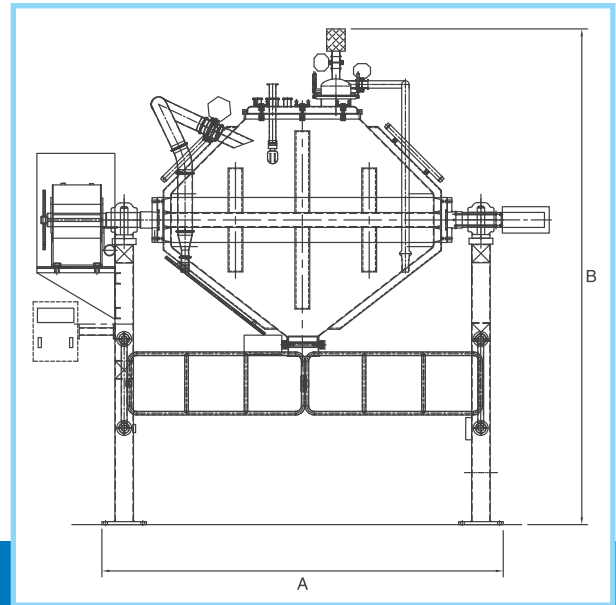

Elevation view

Technical Specifications:

MODEL	WORKING CAPACITY (in Liters)	OVERALL DIMENSIONS (in mm)			MOTOR HP	APPROX. WEIGHT (in kg)
		Length	Width	Height		
TAP-UB-10 (Universal model for Lab Blenders)	Interchangeable bowl upto 7 L working capacity	1280	1150	1550	1.5	500
TAP-UB-20 (Universal model for Lab Blenders)	Interchangeable bowl upto 14 L working capacity	1280	1150	1550	1.5	650
TAP-OB-100	70	2470	800	2000	3	800
TAP-OB-150	110	2470	800	2000	3	1000
TAP-OB-300	210	2200	1000	2400	3	2000
TAP-OB-500	350	2500	1000	2400	5	2600
TAP-OB-750	530	2510	1000	2400	5	2700
TAP-OB-1000	700	2510	1000	2400	5	2900
TAP-OB-1200	840	3300	1200	4500	7.5	3000
TAP-OB-1500	1050	3200	1800	4500	10	4000
TAP-OB-2000	1400	4450	2500	4800	15	5000
TAP-OB-5000	3500	4450	2500	4800	20	5000
TAP-OB-8000	7000	5900	2900	7000	25	5500
TAP-OB-16000	11200	4400	3600	5200	30	7000

Customised sizes available on request

Conta Blender used in Industries:

- Pharmaceutical ■ Nutraceutical
- Food ■ Chemical
- Cosmetics

DOUBLE CONE BLENDER

Tapasya's Double Cone Blender is an efficient and versatile equipment for mixing of powder such as pharmaceutical excipients, various chemicals, food products homogeneously. With an effective volume for optimum homogeneity between 35-70% of gross volume, and a SLANT double cone design that eliminates dead spots, this Double cone blender is ideal across various industries including pharmaceutical, food, chemical, cosmetics, etc.



Features:

- Conical shape and elongated plane at both ends enables uniform mixing and easy discharge
- The cone is statically balanced which protects the gear box and motor from any excessive load
- Powder is loaded into the cone through a wide opening and discharged through a butterfly or a Slide valve
- Depending upon the characteristic of the product, paddle type baffles can be provided on the shaft for better mixing, uniform blending and de-agglomeration
- Contact parts are made of SS 304 or SS 316L
- Flame proof electricals can be provided
- 'Slant' design
- Variable speed option available 70%~
- Dust free bin charging system



Asymmetric Double Cone Design



Sanitary Butterfly Valve

Benefits For You:

- Homogenised blending of solid components
- Advanced design with custom made additional features for varying speed, safety (flame-proof) and varying capacities
- Minimal material handling
- Ideal for various applications in solid mixing



Double Pillar Mounted



Single Pillar Mounted

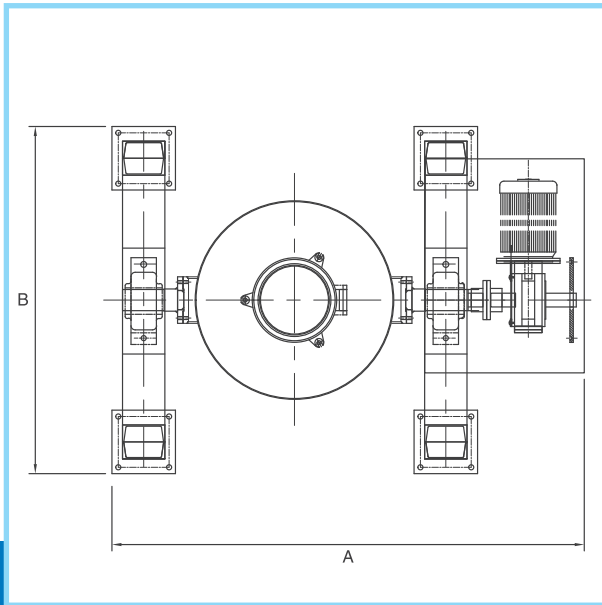

Plan view

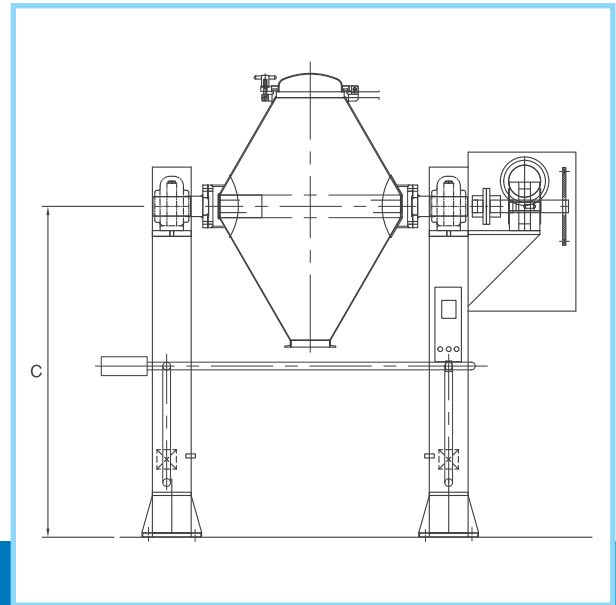

Elevation view

Technical Specifications:

MODEL	WORKING CAPACITY (in Liters)	OVERALL DIMENSIONS (in mm)			MOTOR HP	APPROX. WEIGHT (in kg)
		Length	Width	Height		
TAP-UB-10 (Universal model for Lab Blenders)	Interchangeable bowl upto 7 L working capacity	1280	1150	1550	1.5	500
TAP-UB-20 (Universal model for Lab Blenders)	Interchangeable bowl upto 14 L working capacity	1280	1150	1550	1.5	650
TAP-DC-75	53	1200	950	1650	2	800
TAP-DC-150	105	2000	1200	2250	3	1000
TAP-DC-300	210	2100	1400	2350	5	2000
TAP-DC-500	350	2350	1500	2500	7.5	2600
TAP-DC-1000	700	2700	1800	3000	10	2900
TAP-DC-2000	1400	3250	2400	3550	15	3800
TAP-DC-4000	2800	4400	3000	4800	20	5000

Customised sizes available on request

Double Cone Blender used in Industries:

- Pharmaceutical
- Nutraceutical
- Food
- Cosmetics

RIBBON BLENDER

Tapasya's Ribbon Blender is a light duty, compact blender is designed to achieve convection mechanism of blending powder components which are pre-processed like dried granules, pre-sieved powders etc. It is a LOW SHEAR mixer and ideal for SOLID / SOLID Mixing. Solid / Liquid mixing can also be achieved when high shearing force is not desired.



Features:

- Available in two shapes - U & W
- U-for Low to Medium volume Capacity (single shaft)
- W-for Large to Mega volume Capacity (double shaft)
- Batch size based on 65% of Blender volume
- All contact parts in SS 316L
- Designed to avoid Cross contamination with Monoblock Design
- Bearing mounted on lanterns out of mixing zone
- Air purge on the side entry seals
- Meets all cGMP/cGEP standards
- Continuous Ribbon design for complete discharge
- Variable frequency drive for fine tuning the Shear energy
- Belt driven power transmission
- Reduced material handling with Top mounted charging port and Side discharge arrangement
- Paddle style agitator instead of Ribbon for Blending fragile materials
- Lance type injectors for liquid spraying



Pneumatic Discharge



Air Purged Sanitary Sealing

Benefits For You:

- Homogenised blending of solid components
- Specially designed to avoid cross contamination
- Low maintenance
- Low noise blender
- Occupies less space
- Minimal material handling



Double Hex Ribbon Blade

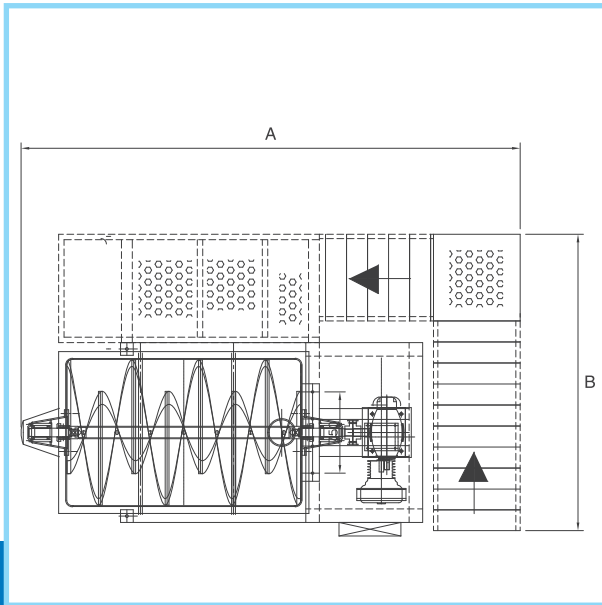

Plan view

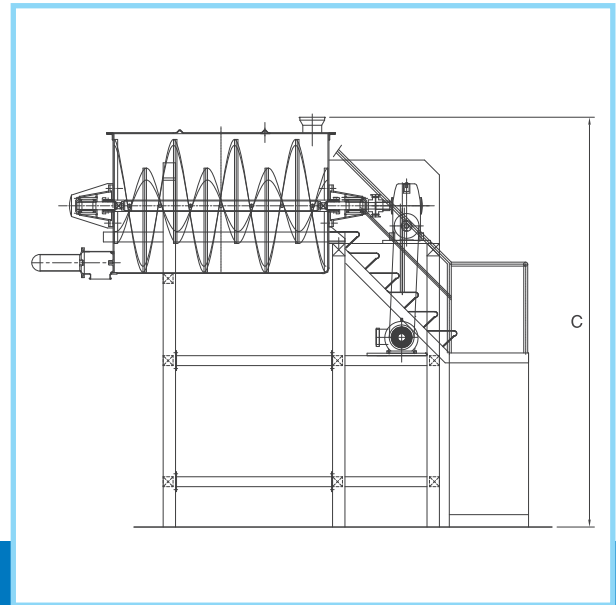

Elevation view

Technical Specifications:

MODEL	WORKING CAPACITY (in Liters)	OVERALL DIMENSIONS (in mm)			MOTOR HP	APPROX. WEIGHT (in kg)
		Length	Width	Height		
TAP-RB-40	26	1500	600	1100	2	550
TAP-RB-100	65	1000	800	1200	3	600
TAP-RB-300	195	2000	1100	1200	3	1200
TAP-RB-500	325	2500	1200	1300	7.5	1600
TAP-RB-1000	650	2700	1300	1800	10	2800
TAP-RB-2000	1300	3200	1400	2300	15	4000
TAP-RB-5000	3250	3600	1500	2500	25	4500

Customised sizes available on request

Double Cone Blender used in Industries:

- Pharmaceutical
- Nutraceutical
- Food
- Chemical
- Cosmetics

PLOUGH SHEAR MIXER

Tapasya's Plough Shear Mixer is designed for ordered heavy duty mixing of both Dry and Wet materials. The special design of shovels with broad ends and pointed tips facilitates good penetration and shuffling of the mass within. Penetration followed by agitation of the mass in quick succession of the specially designed blades results in homogeneity of powder mass both in dry and wet stages. Appropriate dough formation is reached in later process. Centrally mounted chopper will then operate to obtain wet granules of uniform size. Mixed homogeneous mass can be easily discharged from bottom of the mixing drum which is provided with a flush fit discharge port.



Features:

- Batch size based on 70% of blender volume
- Cross Contamination is completely eliminated by mounting
- Bearings on lanterns out of mixing zone
- Removable bolt arrangement of Plough Shovels providing easy accessibility to all inside parts of the mixer
- Feeding through a charging port mounted on top of the mixer
- Inspection Doors with safety interlocks
- Reduced material handling due to bottom discharge facility of processed materials
- Choppers provision as an optional feature
- Fully welded plough shovels can also be provided
- Lance type injectors for liquid spraying



Plough Blade



Pneumatic Bottom Discharge



Ergonomically Designed Manhole

Benefits For You:

- Homogenised blending for dry and wet material
- Capacity custom made to your requirements
- Specially designed to eliminate cross contamination & for easy discharge



Strategically placed Chopper



Visual Inspection Port

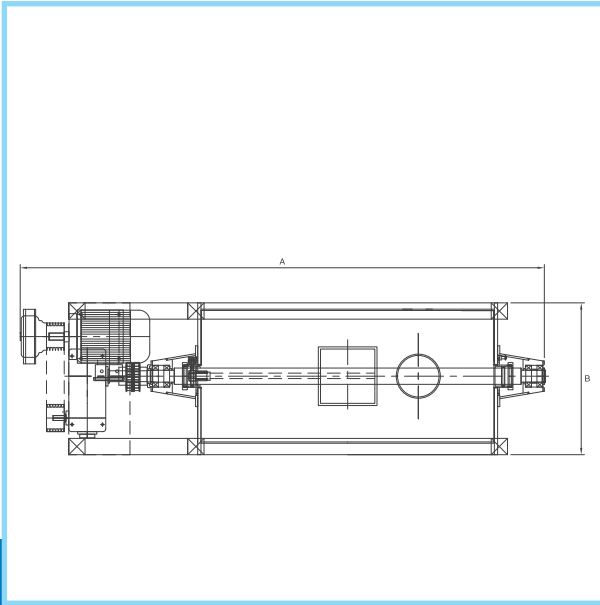

Plan view

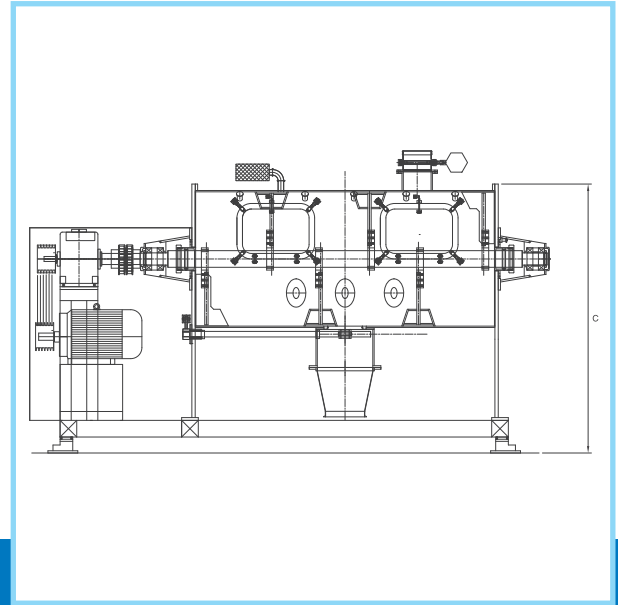

Elevation view

Technical Specifications:

MODEL	WORKING CAPACITY (in Liters)	OVERALL DIMENSIONS (in mm)			MOTOR HP	APPROX. WEIGHT (in kg)
		Length	Width	Height		
TAP-PSM-100	65	1000	800	1200	3	600
TAP-PSM-300	195	2000	1100	1200	7.5	1200
TAP-PSM-500	325	2500	1200	1300	10	1600
TAP-PSM-1000	650	2700	1300	1800	25	2800
TAP-PSM-3000	1300	3200	1400	2300	60	4000
TAP-PSM-5000	3250	3600	1500	2500	75	4500

Customised sizes available on request

Plough Shear Mixer used in Industries:

- Pharmaceutical
- Nutraceutical
- Food
- Chemical
- Cosmetics

MATERIAL HANDLING

Material handling is the movement, storage, control and protection of materials, goods and products throughout the process of manufacturing, distribution, consumption and disposal.

ELEVATOR _____ **72**

TIPPER _____ **75**

POWER TRANSFER SYSTEM _____ **78**

IBC (IN-PROCESS BATCH CONTAINER) _____ **81**

PALLET WEIGHING TRUCK _____ **84**

ELEVATOR

Tapasya's Elevator device is custom designed to lift and position any type of container involved in solid dosage manufacturing and also for liquid compounding operation. This system ensures dust free transfer of in-process materials enhancing cGMP standard, and simultaneously eliminating laborious manual operation.

Elevator operates by engaging the container to a semi-circular / single hook / fork type / platform, lift arm attached to a column. The container is then raised or lowered by hydraulic system with built in safety parameters. The four point contact bearing on the column base with a low resistance factor makes it possible to position loaded container by hand radially, to discharge the contents in the process equipments.



Features:

- Closed Column construction with floor and ceiling fastening
- Also available in self standing pivoted execution
- Material of construction is SS clad MS column/SS column
- Adjustable mount stop
- Double acting in-house manufactured Hydraulic Cylinder with 3 stage Fail safe seals
- Cylinder designed for an operating pressure of 100 BAR & has a Hose burst protection system
- Solid Machined trolley made out of 30 MM Machined Frame
- 2 no's 8 MM Ø SS 304 Wire ropes instead of chain
- Lift Lock for safety provided
- Imported Mono Block Power Pack
- Control Cabling and rigid piping included
- CE Certified meeting 19 EN specifications
- Built-in provision for the Vibratory Sifter/ Mill to be electrically connected
- Mechanical & Pneumatic locking for Safety



Multipurpose Material Handling

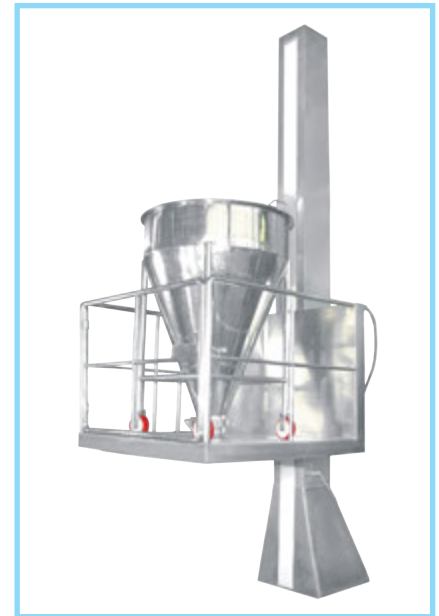

Platform Lift for Multistorey Handling

Benefits For You:

- Dust-free & leak-free transfer operations
- Eliminates manual handling & tedious scooping
- Low maintenance
- Designed to European Safety Standards & cGMP standards
- Varied applications including charging of Sifters, RMG, Compression machine, Packing machine, blenders, etc.
- Variety of Optional features available including full stainless steel construction, Height > 4 mtrs, Rigid design, Mobile design upto 100 kgs load



Mobile Elevator

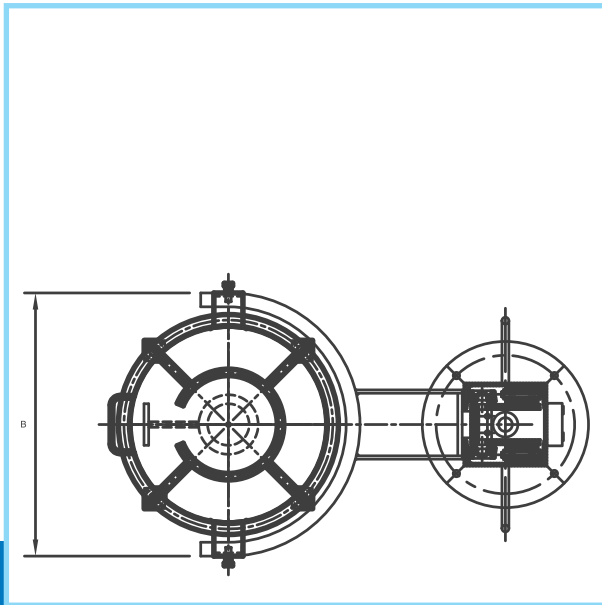

Plan view

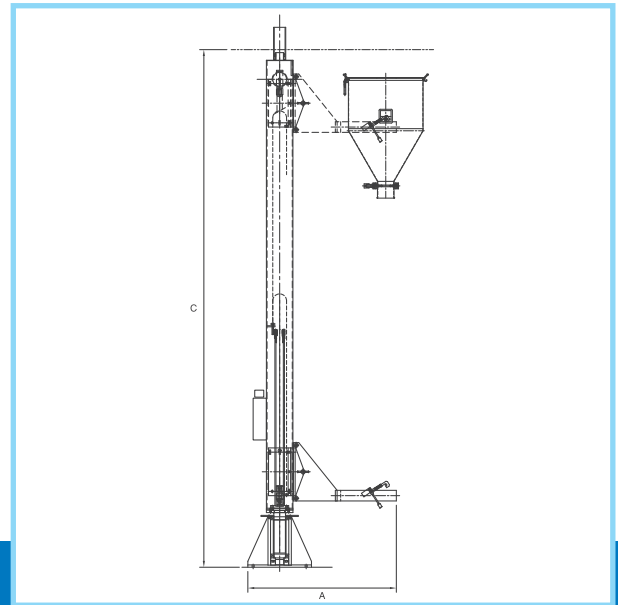

Elevation view

Technical Specifications:

MODEL	WORKING CAPACITY (in Liters)	OVERALL DIMENSIONS (in mm)		MOTOR HP	APPROX. WEIGHT (in kg)
		Length	Width		
TAP-LPD-50	50	1950	900	1.5	600
TAP-LPD-100	100	1950	950	1.5	600
TAP-LPD-200	200	1950	950	1.5	600
TAP-LPD-300	300	2400	1100	1.5	600
TAP-LPD-500	500	2500	1450	1.5	600
TAP-LPD-1000	1000	2700	1550	1.5	800
TAP-LPD-1500	1500	3500	1600	1.5	800
TAP-LPD-2000	2000	3500	1800	1.5	800

Customised sizes available on request

Elevator used in Industries:

- Pharmaceutical
- Nutraceutical
- Food
- Chemical
- Cosmetics

TIPPER

Tapasya's Tipper, a Hydraulically or mechanically operated equipment is used for lifting and tipping granules from the FBE Bowl to granulating equipment and through it to a BIN or an IPC container. The Tipper provides a dust free operation and eliminates tedious scooping or manual handling and is fabricated with high quality SS to impart a cGMP finish.



Features:

- High Quality SS for lift ypkce & discharge cone clamps
- Water tight Control cabinet with hydraulic power pack & electric controls
- Stable Design conforming to cGMP/cGEP Standards
- Hydraulic Cylinder with 3 stage Fail safe seals designed for an operating pressure of 100 BAR
- Solid Machined trolley made out of 30 MM Machined Frame
- 2 no.s 8 MM Ø SS 304 Wire ropes instead of chain
- Lift Lock for safety
- Imported Mono Block Power Pack
- Control Cabling and rigid piping included
- CE Certified meeting 19 EN specifications
- Built-in provision for the Vibratory Sifter/ Mill to be electrically connected
- Hydraulic Tilting arrangement for maintenance free operation
- Limit switches for up & down movement
- Limit switches for stopping the cone in 0 degree & 180 degree
- M.C.B. and overload relays for electrical faults
- Pilot operated Hose Burst Valve on the hydraulic cylinder for hydraulic safety
- Single cone for 2 sizes of FBE Bowl with adaptor
- Timer control for discharge valve
- Mechanical & Pneumatic locking for Safety



180° Tilting

Benefits For You:

- Dust-free transfer operations
- Eliminates manual handling & tedious scooping
- Low maintenance
- Designed to European Safety Standards & cGMP standards
- Variety of Optional features available including
- Free standing unit
- Hydraulic / Mechanical design
- Adjustable stop
- Additional lift column height
- Double Column for heavier loads
- Hydraulic arrangement for tilting
- 180° SWIVEL column
- Pneumatically actuated valve
- Single cone for 2 sizes of FBE Bowl with adaptor



Material Handling without Human Interference

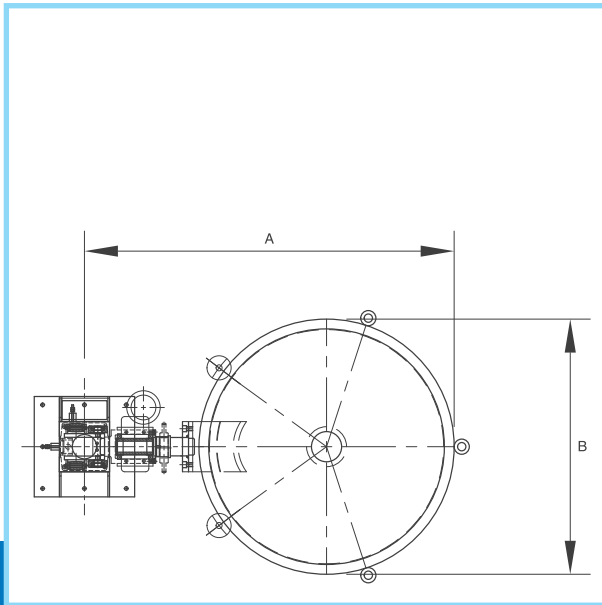

Plan view

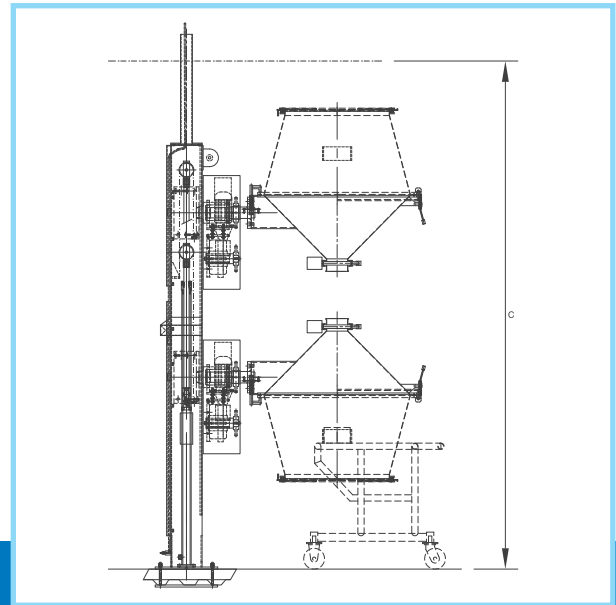

Elevation view

Technical Specifications:

MODEL	WORKING CAPACITY (in Liters)	OVERALL DIMENSIONS (in mm)		MOTOR HP	APPROX. WEIGHT (in kg)
		Length	Width		
TAP-LTD-75	75	2190	1100	3.5	550
TAP-LTD-100	100	2190	1100	3.5	600
TAP-LTD-150	150	2190	1100	3.5	650
TAP-LTD-250	250	2400	1300	4.5	700
TAP-LTD-300	300	2500	1450	4.5	700
TAP-LTD-600	600	2500	1500	4.5	800
TAP-LTD-800	800	2500	1500	4.5	1100
TAP-LTD-1000	1000	2700	1700	6.5	1100
TAP-LTD-1200	1200	2990	1750	6.5	1200
TAP-LTD-1400	1400	2990	1750	6.5	1300
TAP-LTD-1800	1800	3730	1750	6.5	1500

Sizes suitable for all TAPASYA FBE are available

Tipper used in Industries:

- Pharmaceutical
- Chemical
- Nutraceutical
- Cosmetics
- Food

POWDER TRANSFER SYSTEM

Tapasya's Powder Transfer System (PTS) represents an ideal solution for meeting the easy transfer of material by generating and maintaining vacuum in the system. The 100% material can be easily transferred from one process to another in time with minimum engagement of human resources. The yield to yield correlation can be maintained easily with minimum travel time of particles for higher batch sizes in the Pharmaceutical, Nutraceutical, Food and other allied industries. This pneumatically operated system offers safety and hygiene hence cGMP compliant.



Features:

- Pneumatically operated transfer system for powder and granules
- Closed system for dust free operations
- Buffer vessel provision to avoid choking & assist in continuous feeding of product
- Considerable reduction or elimination of operator exposure
- Reduction in manpower required for charging
- Improved agitation and thus reduced batch time, through controlled material addition
- Reduces solids handling and eliminates hoists and handling equipment
- Easier to clean than conventional vacuum conveying equipment; CIP available
- Automatic pulse filter cleaning mechanism for improved process efficiency
- Integrated HIM system for automated process
- Multiple options available for different applications: Fixed, Mobile & Wall mounted
- Existing process steps can be linked to each other

Benefits For You:

- Effective and reliable system for transfer of powders and granules
- Dust free operations
- Batch time reduction
- Time savings
- Manpower savings
- Easy cleaning and maintenance

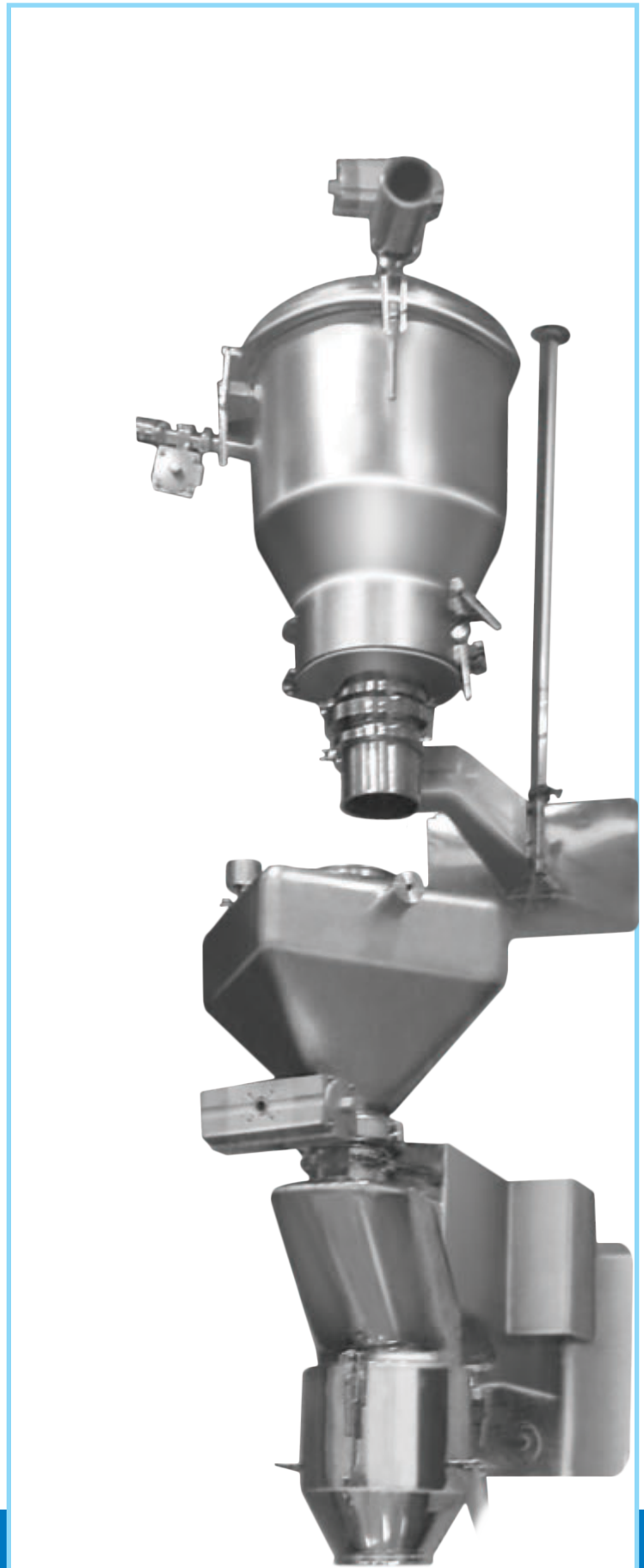

PTS integrated with Cone Mill

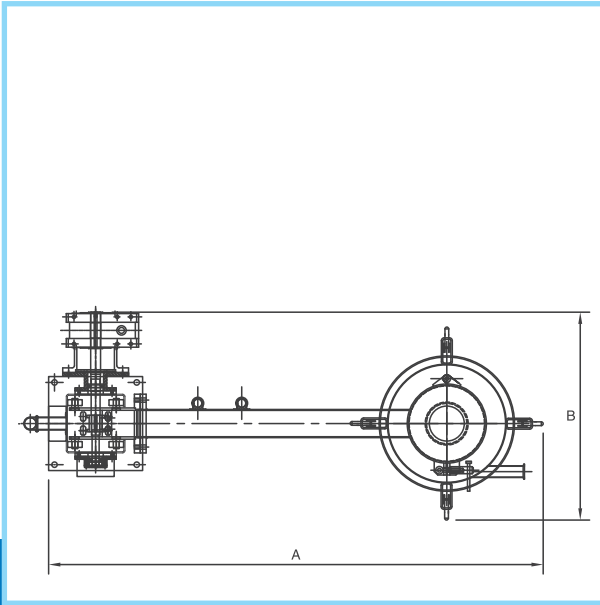

Plan view

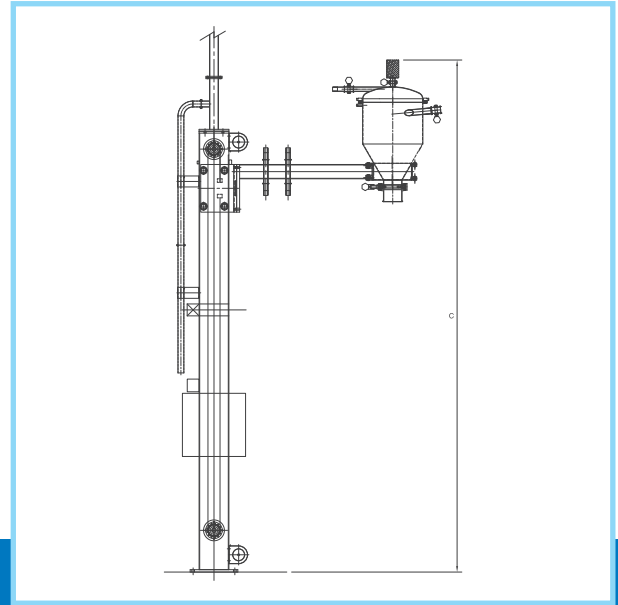

Elevation view

Technical Specifications:

MODEL	WORKING CAPACITY (in Kg/Hr)	OVERALL DIMENSIONS (in mm)		MOTOR HP	APPROX. WEIGHT (in kg)
		Length	Width		
TAP-VTS-100	100	1700	850	5	500
TAP-VTS-500	500	2000	1000	10	800
TAP-VTS-1000	1000	2600	1000	20	1000
TAP-VTS-2000	2000	2600	1000	25	1200

Customised sizes available on request

Powder Transfer System used in Industries:

- Pharmaceutical
- Nutraceutical
- Food
- Chemical
- Cosmetics

IN-PROCESS BATCH CONTAINER (IBC)

Tapasya offers a variety of containers for your 'In-Process' material handling and storage needs. Each of these containers can be custom designed to meet your specifications of volume / weight to be contained within and transfer of material.

Tapasya offers Circular Conical IBC, Circular Drums & Conta Bin / Blending IBC of varying capacities.



Features:

Circular Conical IBC:

- Hermetically sealed intermediate Product Container
- Ergonomically designed handles and 60o angle of response for easy of material flow and handling
- P.U. Wheels and an inside / outside surface finish of <math><0.3 Ra</math>

Circular Drums:

- Perfect dimensions for loading / unloading operations for to & from blenders
- Built-in level-sensing port
- P.U. Wheels and an inside / outside surface finish of <math><0.3 Ra</math>

Conta Bin / Blending IBC:

- Square Hermetically sealed bins with loose detachable trolley
- Ideal for size 50L to 800L
- P.U. Wheels and an inside / outside surface finish of <math><0.3 Ra</math>



Drum Bin



Toolless Assembly Sanitary Valve

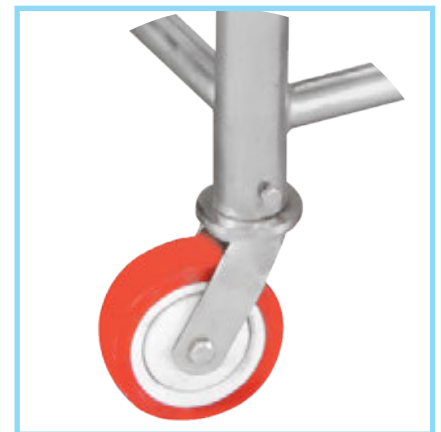

PU Wheel

Benefits For You:

- Convenience in Production units
- Durable & Safe Storage Option
- Easy handling & Movement of Raw materials and In-Process Materials



Circular Conical IBC



Conta Bin / Blending IBC

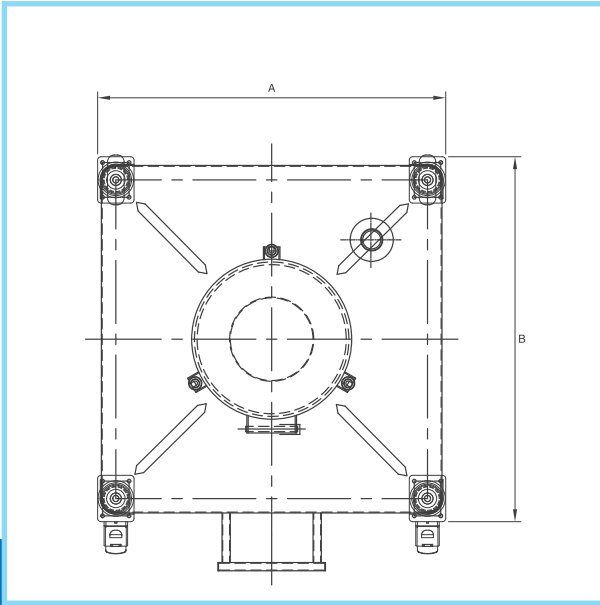

Plan view

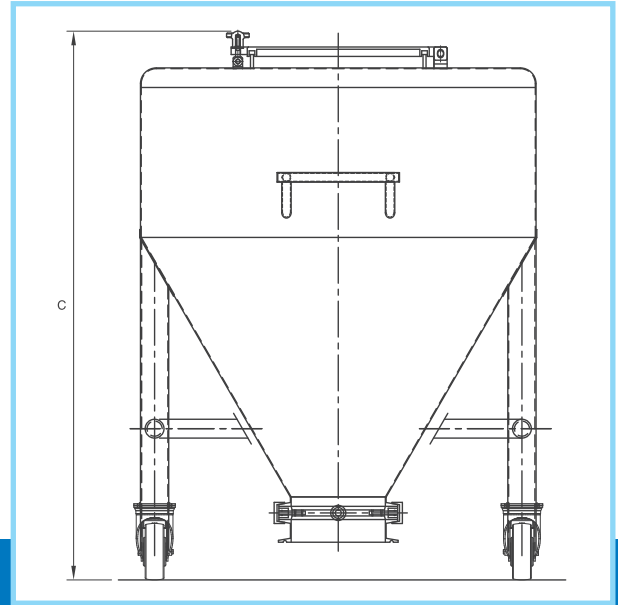

Elevation view

Technical Specifications:

MODEL	WORKING CAPACITY (in Liters)	OVERALL DIMENSIONS (in mm)			APPROX. WEIGHT (in kg)
		Length	Width	Height	
TAP-IBC-50	40	930	610	710	60
TAP-IBC-75	60	940	700	900	80
TAP-IBC-110	90	950	750	950	100
TAP-IBC-130	105	1020	750	1000	110
TAP-IBC-160	130	1220	880	1010	120
TAP-IBC-210	170	1220	880	1130	140
TAP-IBC-250	100	1220	880	1130	150
TAP-IBC-310	250	1230	990	1130	170
TAP-IBC-500	200	1100	1100	1400	200
TAP-IBC-1000	400	1200	1200	1650	250
TAP-IBC-1500	600	1400	1400	1700	300

Customised sizes available on request

In-Process Batch Container used in Industries:

- Pharmaceutical
- Nutraceutical
- Food
- Chemical
- Cosmetics

PALLET WEIGHING TRUCK

Tapasya's Mobile Weighing System, a compact and portable system, is a superior option to the typical fixed weighing platforms in the production area. Widely used in the Pharmaceutical, Nutraceutical and other allied industries, this system eliminates the need for to & fro movement of ingredients and finished products for merely weighing purposes as it enables online weighing facility.



Features:

- Top Quality
- Stable Design
- High load bearing capacity
- New Rapid action lift
- Battery operated
- FLP design for explosive areas
- Constructed using SS 304 making it corrosion resistant

Benefits For You:

- Accurate Online Weighing
- Compact & Portable
- Convenient in Production units
- Durable & Safe Weighing Option

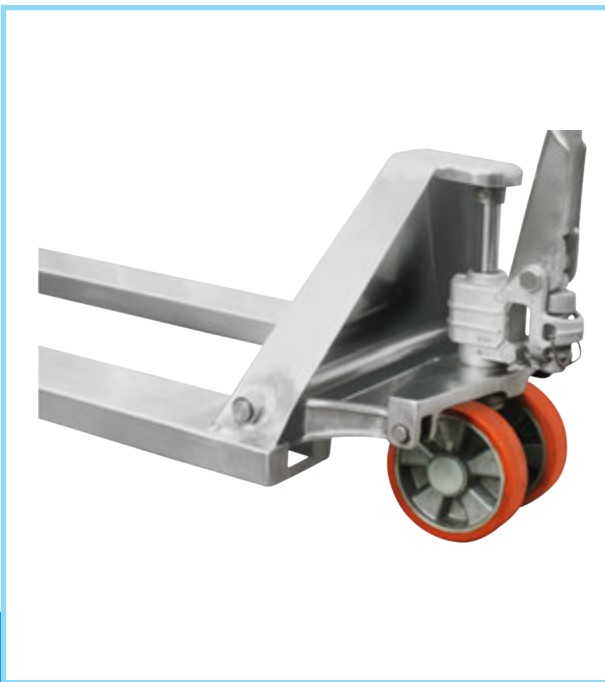

High Load Bearing Capacity PU Wheel



Weighing Display

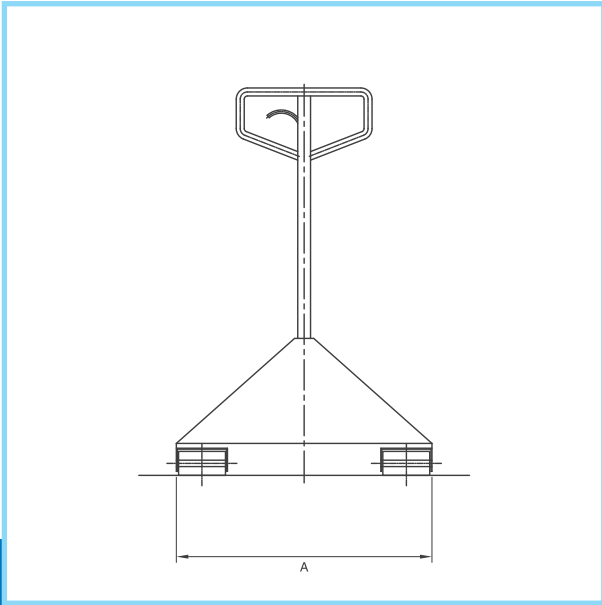

Front view

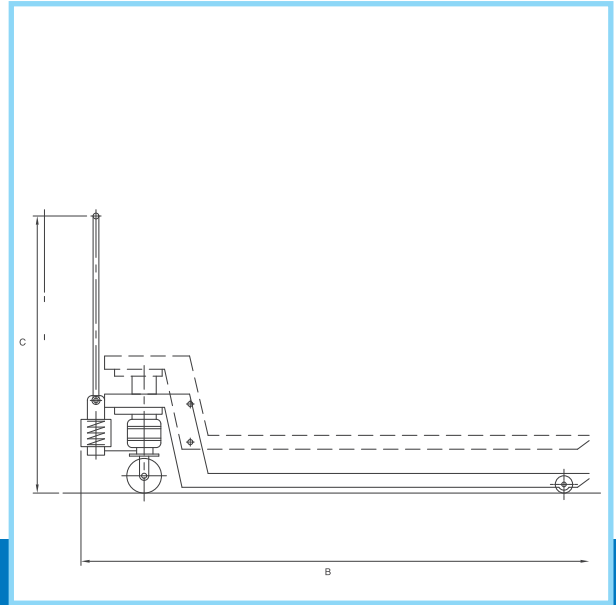

Side view

Technical Specifications:

MODEL	WORKING CAPACITY (in liters)	OVERALL DIMENSIONS (in mm)			APPROX. WEIGHT (in kg)
		L	B	H	
TAP-PWT-1000	1000	800	2200	1200	100
TAP-PWT-2000	2000	800	2200	1200	120
TAP-PWT-3000	3000	1000	2200	1200	150
TAP-PWT-4000	4000	1000	2200	1200	180

Pallet Weighing Truck used in Industries:

- Pharmaceutical
- Nutraceutical
- Food
- Chemical
- Cosmetics

CLEANING

Equipment should be cleaned, maintained and sanitized at appropriate intervals for the sustaining safety, identity, strength, quality, or purity of the drug product beyond the official or other established requirements.

BIN WASH SYSTEM _____ **88**

CIP / WIP SKID _____ **91**

BIN WASHING SYSTEM

Tapasya's Bin Washing System comes as a stand-alone or a completely integrated system designed to clean all sizes of IBC's with minimum human intervention. The system is specifically designed for Cleaning & Drying the Bins in a pre-validated manner and comes with an efficient telescopic arm enabled spray nozzle for cleaning the internals of the Bins and multiple nozzles for external cleaning.



Features:

- Single system for Wash & Dry operation with an Option of Open & Closed type Bin Wash system
- Turntable arrangement for lower platform
- Complete enclosure through the provision of Inflatable seal
- 10 bar pressure design for maximum cleaning
- Air handling unit in Closed type Wash System for drying operation
- Infrared arrangement in the Open type Wash System
- Easy integration with a Tapasya CIP skid to provide a systematic cleaning operation through Recipe control
- Automated operation through PLC system
- Systematic drainage arrangement for proper collection of liquids
- Automatic loading and unloading options for completely Automated operation
- Options available for 'Through the wall' design, Sight glass, Electronic opening of Upper & Lower valves of Bins



Telescopic Spray Nozzle for Internal Bin Washing



Turn Table Assembly

Benefits For You:

- Provides Quick Clean Operation with Minimum Water Consumption
- Maximum Cleaning of IBC of Every Size & Type
- Fully Automated With Minimal Human Intervention
- Custom Made for Your Requirements



Recipe Controlled Automated Operation

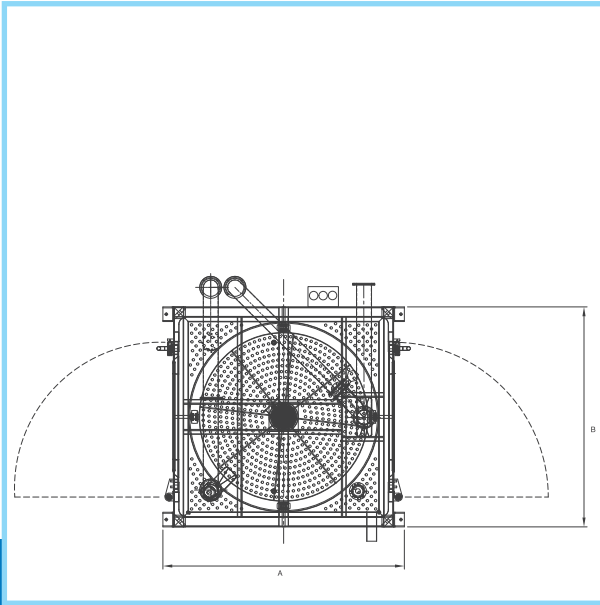

Plan view

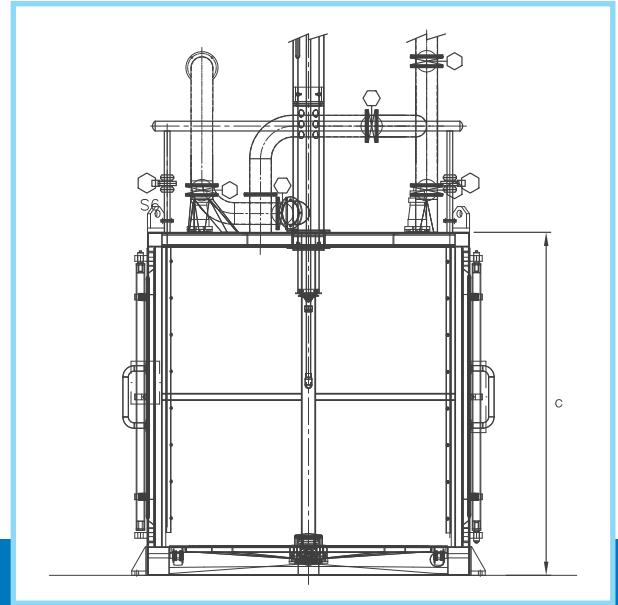

Elevation view

Technical Specifications:

MODEL	OVERALL DIMENSIONS (in mm)			APPROX. WEIGHT (in kg)
	Length	Width	Height	
TAP-BWS-O	2800	2800	3000	1500
TAP-BWS-C	3200	2800	3200	3500

Customised sizes available on request

Bin Washing System used in Industries:

- Pharmaceutical
- Nutraceutical
- Food
- Chemical
- Cosmetics

CIP / WIP SKID

Clean-in-place (CIP) / Wash-in-place (WIP) technology from Tapasya offers reliable cleaning of process equipment and piping with fully-automated, State-of-art' technology.

Tapasya's CIP / WIP system is designed to achieve efficient circulation of cleaning medium such as purified water, hot water, detergent solution with special provision of sanitization to emphasize purity. from Tapasya means you can trust that your stainless steel tanks, pumps, valves and controls have been selected with special attention for - attention that minimizes costs, maximizes productivity and efficiency, and emphasizes purity.



Features:

- Complete Clean system
- Proper CIP design with regulated time, flow & temperature to thoroughly remove residue
- Custom designed to suit individual plant & application requirements along with its control systems
- Complete automated process through PLC system for Recipe type functions
- User-friendly Maintenance design for Ergonomics
- Multiple options available for Heating, Mobility & Material of construction

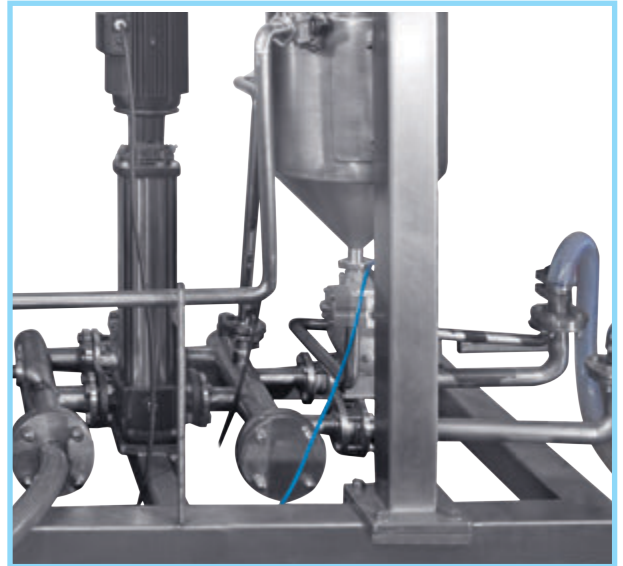

Sanitary Piping

Benefits For You:

- Reduced Operating time & costs
- Customised Design as per Your Requirements
- Documentation support to comply with Regulatory & Validation Requirements
- Easy Maintenance & Low Maintenance Costs

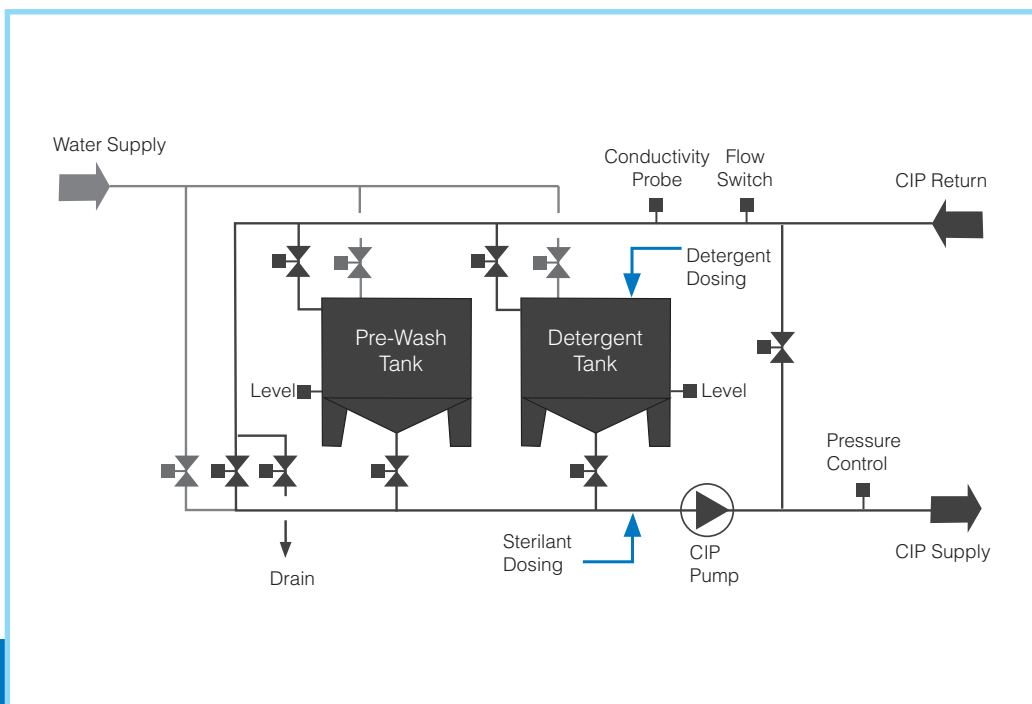

CIP SKID Schematic

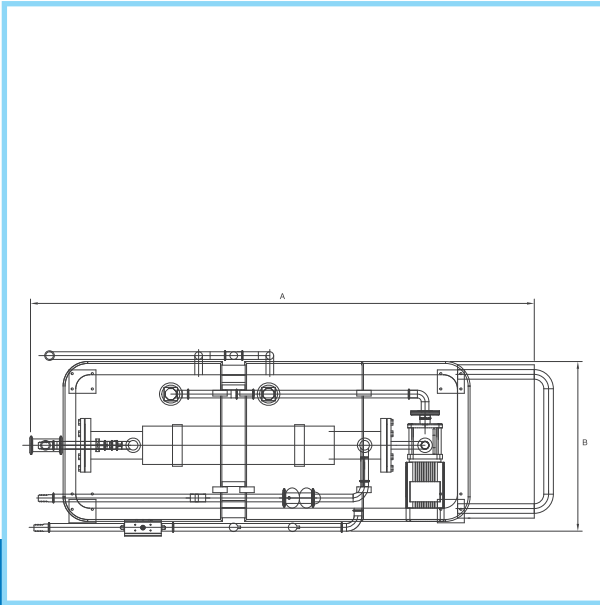

Plan view

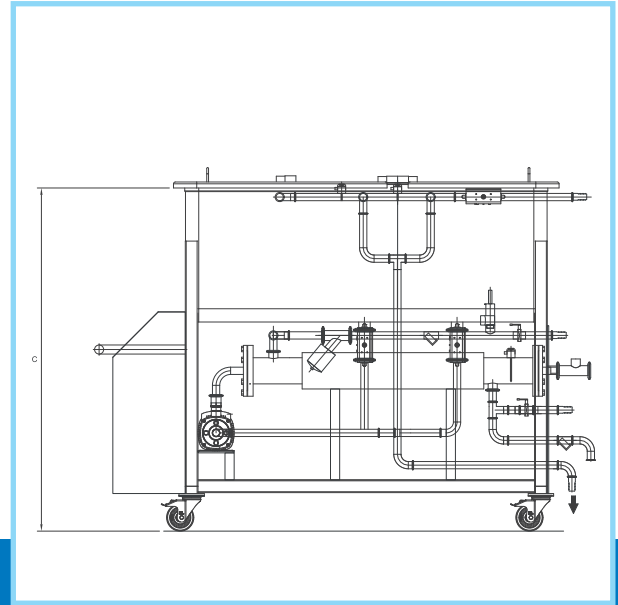

Elevation view

Technical Specifications:

MODEL	OVERALL DIMENSIONS (in mm)			APPROX. WEIGHT (in kg)
	Length	Width	Height	
TAP-WIP	3000	2700	3000	800

Customised sizes available on request

CIP SKID used in Industries:

- Pharmaceutical
- Nutraceutical
- Food
- Chemical
- Cosmetics

TABLET COATING

AUTOCOATER

96

AUTOCOATER

Tablet coating is the last critical step in the tablet production cycle. Uncoated compressed tablets containing API are placed into perforated drum. Then aqueous or solvent based material solution is sprayed onto them to form a thin film coat.

“TAPASYA COATER” utilizes the principle of spraying of coating liquids with optimum atomization with maximum even distribution of coating solution on the tablet surfaces with properly heated clean Process air through the bed to provide rapid drying and control of dust and coating liquid. Thus, the efficient and uniform coating and drying takes place between coats.



Objective:

- To mask odour, taste or colour of the drug
- To provide physical and chemical protection to the drug
- To control release of the drug from tablet
- To protect acid sensitive drug from gastric environment of the stomach
- To avoid chemical incompatibility



Features:

- Compact design
- Suitable for both sugar and film coating
- 316 L Product contact surface
- Sealed access doors
- Quick release plenums
- High performance mixing baffles
- Atomizing air and Pattern can be controlled independently
- Spray nozzles are Anti-bearding type
- PLC based HMI based recipe control
- Fully perforated drum standard
- WIP available. Easy to clean modular design
- Option of both fixed drum and interchangeable drum design
- Tailored Air treatment units specific to the project

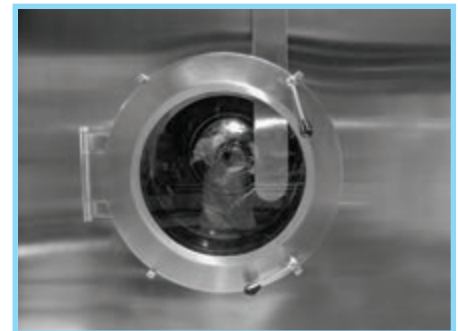

Benefits for you:

- State of the art coater with perforated drum technology
- Single unit is compatible for sugar and film coating
- Easy operation
- Faster and uniform coating
- Uniform surface finish giving good logo clarity
- Easy maintenance
- To avoid chemical incompatibility



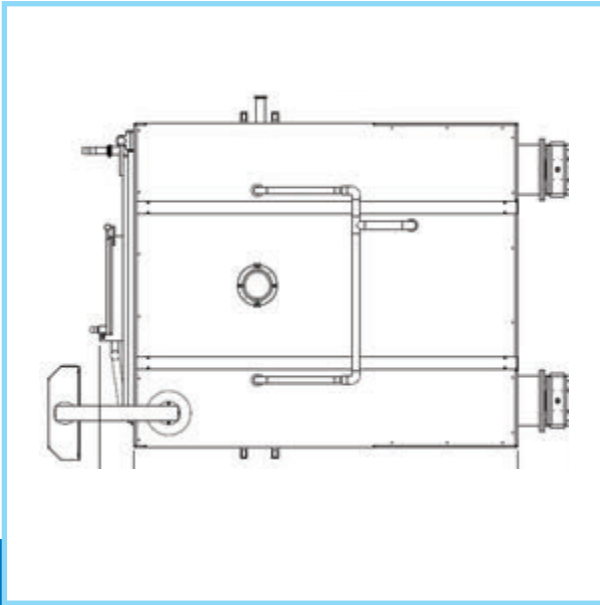

Plan view

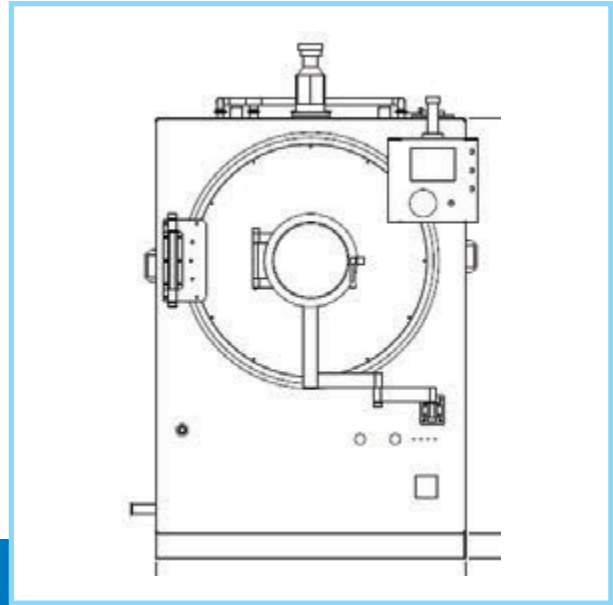

Elevation view

Technical Specifications:

MODEL	CAPACITY (in Kg)	PAN DIAMETER in mm	PAN SPEED (in RPM)	OVERALL DIMENSIONS (in mm)			PAN DRIVE MOTOR (IN HP)	AIR CAPACITY (CFM)
				Length	Width	Height		
TAP-AC-18	10	458	3-25	1035	1020	1570	1	100
TAP-AC-24	20	610	2-20	1000	1200	1800	1	300
TAP-AC-36	75	915	2-10	1350	1450	1900	3	1200
TAP-AC-48	150	1220	2-10	1720	1630	2220	5	2500
TAP-AC-60	350	1575	2-10	2120	1920	2570	15	4500

Interchangeable drum options:

TAP-AC-18: with 12", 14" & 18" perforated drums

TAP-AC-26: with 24" & 26" perforated drums

TAP-AC-30: with 24" & 30" perforated drums

TAP-AC-36: with 24" & 36" perforated drums

Auto coaters used in Industries:

- Pharmaceutical
- Nutraceutical
- Food
- Chemical

INTEGRATED SYSTEMS

GRAVITY TRANSFER SYSTEM

The most traditional yet the most robust system in Granulation suites which utilizes material handling system for product transfer. The system is particularly beneficial where the ingredients are dosed individually with good flow rate. The particles follows the integrated granulation track and hence results in minimal human intervention with qualitative improvement.

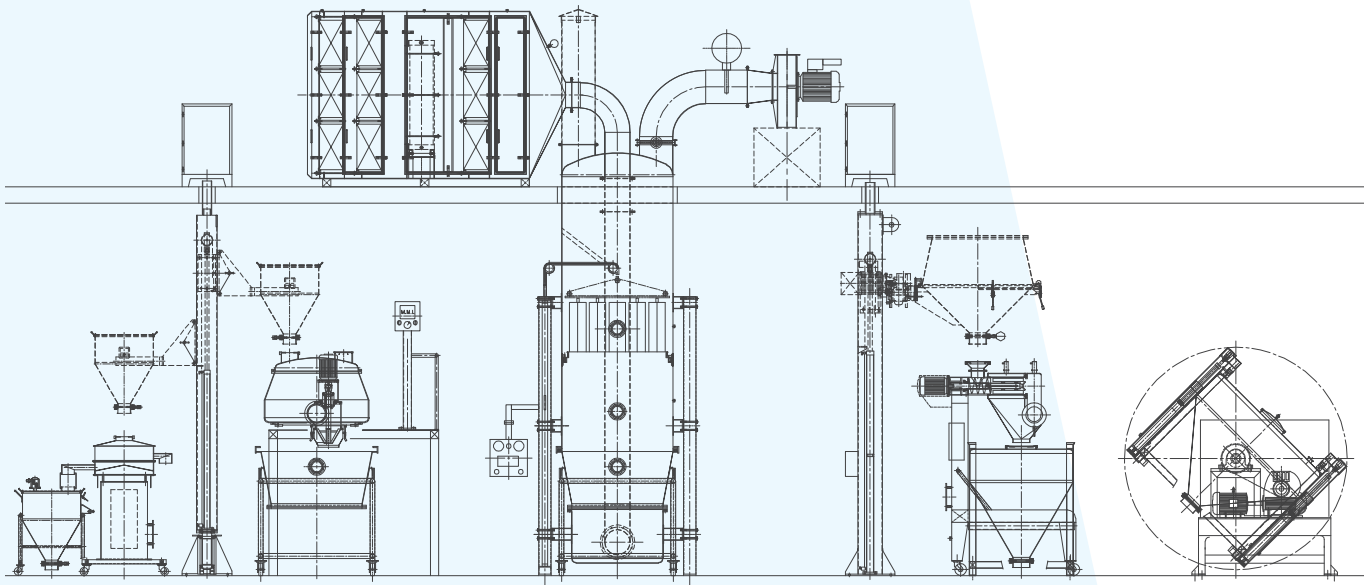

Granulation Suites — Gravity Transfer System

INTEGRATED SYSTEMS

MULTI-LEVEL TRANSFER SYSTEM

Downstream approach with smaller footprint every floor, this Suite best suited for much specialised operation where the ordered process is the requirement for larger capacity range. The equipments are integrated with each other through the levels with automated systems for automatic operation of the Suite. The particles follow the integrated granulation track with minimum travel distance to achieve and maintain the integrity of the process. Critical parameters like cleaning validation can be achieved easily.

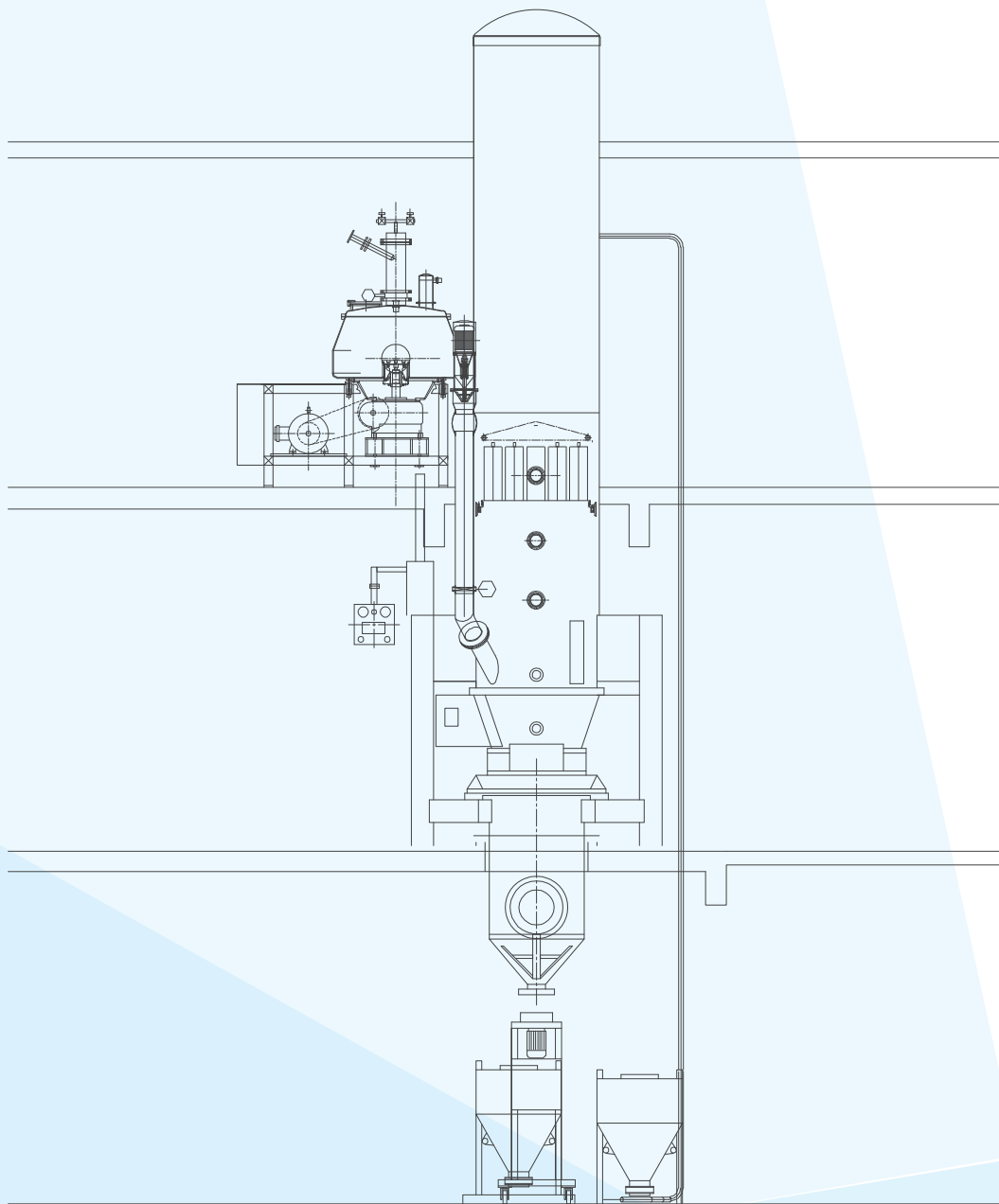

Granulation Suites — Multi-Level Transfer System

INTEGRATED SYSTEMS

VACUUM TRANSFER SYSTEM

Vacuum transfer suite is the Quick, direct & the most efficient system which utilizes vacuum system to transfer product. Equipments in the suite are Integrated with each other with special fitments to achieve and maintain the media(Vacuum) of material transfer which ensures shorter batch times & more productivity.

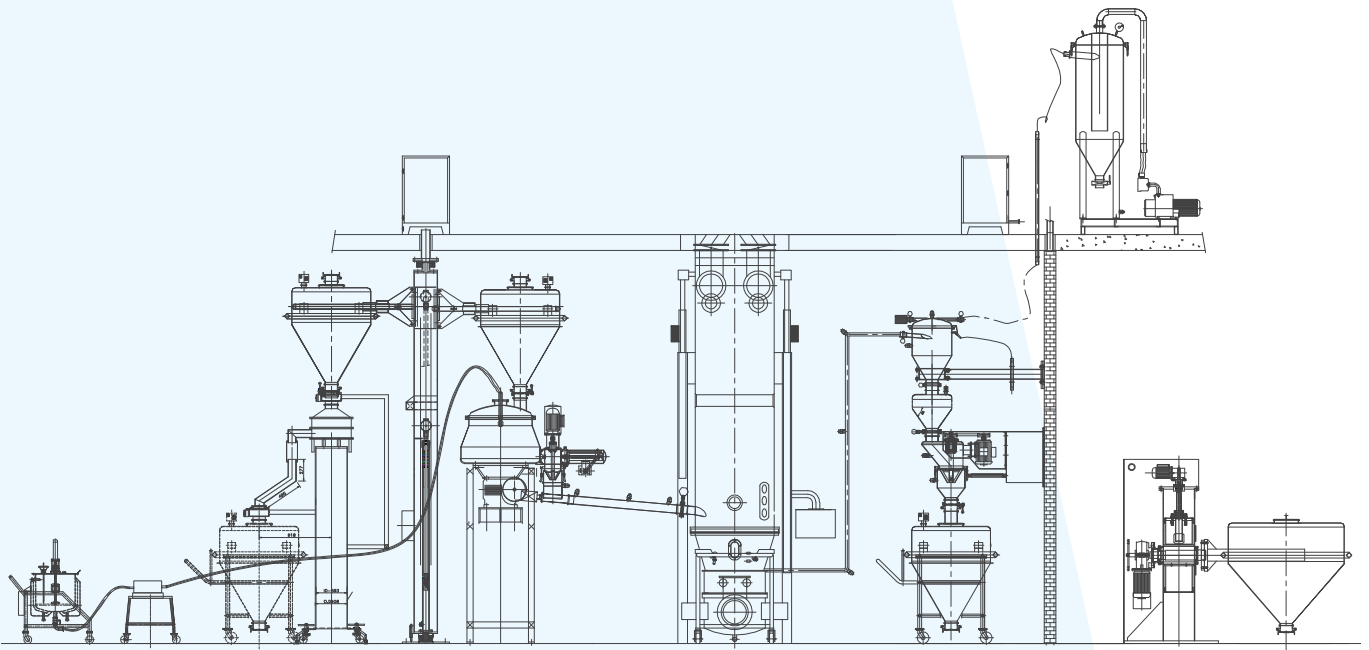

Granulation Suites — Vacuum Transfer System

DOCUMENTATION

Tapasya assures quality product with good documentation practices

In a cGMP environment documentation needs to meet certain requirements to ensure product quality and product safety. The cGMP regulations from FDA, PIC/S and EU all include mandatory sections on documentation.

Documentation provides both:

- Information on when, where, who, why, and how to complete tasks, and
- Evidence proving that the tasks have been completed as they should be

Documents provide the information or evidence or may serve as an official record.

Tapasya's documents includes:

Drawings

- Assembly and Erection Drawings
- Equipment Support Drawings
- Drawing of schematic and piping arrangements
- Drawings for Air Handling Unit Instrument
- Data sheets loop diagrams
- General Assembly drawings
- Electrical and Pneumatic drawings
- Process & Instrumentation diagrams & necessary layouts
- Final As-built Drawing
- Contact surface area drawing

Certificates

- Material of construction reports
- Certificates for all direct / indirect product contact surfaces
- Instrument calibration reports or certificates
- Integrity test certificate
- Guarantee / warranty certificates for the equipment and bought-out items

Operation manuals

- Operation and maintenance manuals for the main equipment as well as all the bought out items
- Operation and maintenance manuals for the major components Software ladder logic / operation and controls
- Software manual
- Instrument manual
- Equipment manual and trouble shoot guide manuals
- Interlock description flow charts for operation and maintenance

Protocols and qualification documents

- Factory Acceptance Test protocols
- Design Qualification
- Installation Qualification
- Operation Qualification
- Installation instructions/ guidelines
- Recommended SOP's for operation, cleaning and maintenance



“Shield 12” Granulation Suite

With pharmaceutical fraternity innovating new chemical entities (NCEs); safety standards for oral solid dosages (OSDs) have come in intense focus. Keeping up with needs to deliver solution Tapasya introduces SHIELD-12 with synergy of latest technology – a suit with tolerance for 12 bar explosion and through the wall designed close loop containment manufacturing.

Need in Previous Design:

A. Safety for integrated granulation and drying suites

- Safety of integrated systems with respect to pressure enhancement is not confirmed by the conventional design as the line has been designed for low pressure tolerance i.e. approximately 2 Bar
- The creation of static charges or the use of organic solvent in the process may lead to explosion
- The explosion leads to increase in pressure in the processing area or closed loop of machine, if the machine design is not according to capacity of pressure tolerance, the explosion may affect the user or the nearby area
- It leads to major accident in processing area
- The main objective of the integrated granulation and drying suites is the safety of the operator and the area
- Contamination of the product due to conventional granulation suites is also one of the factor which induces need/ challenges for innovation of this technology

B. Safety and the environment

- The exposure of oncology products to the environment leads to its adverse effects on human being as well as to the environment
- The main risk of material escaping into the environment exists whenever a connection between those pieces of equipment needs to be made or broken, when a sample needs to be taken, and last, but not least, when the machines need to be cleaned after the end of a manufacturing campaign



Key Features:

A. Improved safety for integrated granulation and drying suites

- Extensive safety confirms pressure enhancement effects and identifies safe design limits for integrated systems
- This research has shown conclusively that if an explosion occurs during the transfer operation in an integrated system where a granulator is connected directly to a fluid bed dryer without an explosion isolation valve, the secondary explosion pressures in the granulator can be significantly higher than in the fluid bed



B. Safety when using organic solvents

- Explosion pressure in the granulator is dependent on the volumes of the two vessels and that the length and diameter of the interconnecting duct is critical in ensuring that the pressure remains within safe limits

C. Safety and the environment

- Full compliance with national, local and in-house regulations, 12 Bar Systems offers a range of emission control options including solvent recovery systems, outlet filters and full containment plants
- Equipment can be supplied to meet explosion-proof and pressure shock standards as required

D. Integrated granulation and Drying suites:

- Special integrated system for sampling of the product during formulation of oral solid dosage form has been introduced
- Special provisions for cleaning operation have been introduced

Quantitative Results:

- Improved safety for integrated granulation and drying suites
- Safety when using organic solvents
- Safety to the user as well as environment
- Integrated granulation and Drying suites (Containment)



OUR PARTNERS

Access Special Technology, with our International Partners



ANDOCKSYSTEME, GERMANY

Andocksysteme specializes in containment interfaces and accompanying components. With experience, creativity and expertise ANDOCK has become a trendsetter for future oriented containment solutions. Based on our proven versatile product portfolio, ANDOCK can offer the appropriate containment system for every need. This applies to conventional stainless steel components, advanced single-use components as well as combinations thereof.

Tapasya partners with Andock in India for sales support.



FILL TECHNIC, TURKEY

Fill Technic is specialised in manufacturing and supply of advanced technology machinery to produce machines for beverage industry. Fill technic gives turn-key solutions in bottling lines.

Tapasya partners with Fill Technic for bottling lines and packing systems in India for Sales support

OUR PRESENCE



Tapasya Engineering Works Pvt. Ltd.

Plot A / 212, Road No.30, Wagle Industrial Estate, Thane - 400604, India.

T: +91 22 6157 9400 | F: +91 22 2582 5243

E: sales@tapasyaindia.net



Scan the **QR Code**
using your smartphone to visit
www.tapasyaindia.net